



# City Council Meeting

Holly Springs Public Safety Building, Council Chambers  
3235 Holly Springs Pkwy. Holly Springs, GA 30115  
Thursday, May 21, 2026 | 6:30 PM

---

**Ryan P. Shirley, Mayor**

Michael Roy Zenchuk II, Mayor Pro Tem, Ward 3

Kyle Whitaker, Ward 1 | Dee Phillips, Ward 2 | Kevin Moore, Ward 4 | Jeff Wilbur, Ward 5

---

## AGENDA

### I. CALL TO ORDER

### II. PLEDGE OF ALLEGIANCE

*"Veterans of U.S. military services may proudly salute the flag while not in uniform based on a change in the governing law on 25 July 2007."*

### III. INVOCATION

### IV. PRESENTATIONS

- A. Employee Service Recognition – Five Years of Service  
Teresa Rentz
- B. Employee Recognition – Promotion  
Captain John Burns

### V. PUBLIC COMMENTS

### VI. CONSENT AGENDA

- A. May 4, 2026 City Council Meeting Minutes.
- B. April 27, 2026 City Council Special Called Meeting Minutes

### VII. OLD BUSINESS

### VIII. NEW BUSINESS

- A. Memorandum of Understanding between the City of Holly Springs, Georgia and First Baptist Church of Woodstock to establish a collaborative partnership to support the development and implementation of a transitional supportive housing community for homeless single mothers and their children in our community and ratify the Mayor's signature.

- B. Professional Services Agreement between LJA Engineering, Inc. and the City of Holly Springs, Georgia for engineering and capital project management services, and authorize the Mayor to execute the documents pending approval of the City Attorney.
- C. A resolution of the City of Holly Springs, Georgia to amend the Municipal Services Master Fee Schedule.
- D. To Amend the Information Technology Technician Job Description.
- E. Proposal dated May 11, 2026, from SuperHero Fire Protection for an above-ground dry stack fire protection system in the Holly Springs Town Center Parking Deck, in an amount not to exceed \$104,850.
- F. Estimate #0332 from KAM Contracting Southeast, LLC for sanitary sewer changes and stormwater sewer changes in the Holly Springs Town Center in an amount not to exceed \$83,550.
- G. Quote # Q-468973 from Power DMS by NeoGov for a subscription services agreement for the use of state certification and policy management software in an amount not to exceed \$10,784.24.

**IX. REPORTS**

**X. ADJOURNMENT**

**XI. EXECUTIVE SESSION**

- A. Litigation
- B. Real Estate

**City of Holly Springs**  
**City Council Meeting Minutes**  
**May 4, 2026**  
**6:30 PM**

**Elected Officials Present:** Mayor Ryan Shirley, Mayor Pro Tem Michael Zenchuk II, Councilman Kyle Whitaker, Councilwoman Dee Phillips, and Councilman Kevin Moore.

**Elected Officials Not Present:** Councilman Jeff Wilbur.

**Staff Present:** City Attorney Robert M. "Bobby" Dyer, City Manager Robert H. Logan, Assistant City Manager/City Clerk Karen Norred, Community Development Director Nancy Moon, Finance Director Denise Lamazares, Information Technology Manager Tyler Gragg, Chief Tommy Keheley, Deputy Chief Greg Clyburn, and Lieutenant Naveed Babar.

**I. CALL TO ORDER**

Mayor Shirley called the City Council Meeting to order.

**II. PLEDGE OF ALLEGIANCE**

Mayor Shirley led the Pledge of Allegiance.

**III. INVOCATION**

Mayor Pro Tem Zenchuk gave the invocation.

**IV. PRESENTATIONS**

- A. Yard of the Month  
John J Cirolia

**V. PUBLIC COMMENTS**

None.

**VI. CONSENT AGENDA**

- A. April 20, 2026 City Council Meeting Minutes.

Councilwoman Phillips made a motion to approve the consent agenda. Mayor Pro Tem Zenchuk seconded the motion. Motion carried. Yes 4, No 0, Abstained 0.

**VII. OLD BUSINESS**

None.

**VIII. NEW BUSINESS**

- A. Resolution authorizing participation in an Amicus Brief in Chang v. City of Milton on remand before the Georgia Court of Appeals.

Councilwoman Phillips made a motion to approve Item A. Councilman Moore seconded the motion. Motion carried. Yes 4, No 0, Abstained 0.

- B. Quote from North Cherokee Electrical, Inc. for a loop replacement at the intersection of Holly Springs Parkway and Harbor Creek Parkway, in an amount not to exceed \$5,700.

Mayor Pro Tem Zenchuk made a motion to approve Item B. Councilman Moore seconded the motion. Motion carried. Yes 4, No 0, Abstained 0.

- C. Renewal of the Pollution Liability line of coverage with Georgia Interlocal Risk Management Agency (GIRMA).

Councilman Moore made a motion to approve Item C. Councilwoman Phillips seconded the motion. Motion carried. Yes 4, No 0, Abstained 0.

- D. Resolution authorizing the transfer of a service weapon to a former police officer.

Mayor Pro Tem Zenchuk made a motion to approve Item D. Councilwoman Phillips seconded the motion. Motion carried. Yes 4, No 0, Abstained 0.

**IX. REPORTS**

- A. Monthly Departmental Reports

**X. ADJOURNMENT**

Mayor Pro Tem Zenchuk made a motion to adjourn the meeting and move into executive session for the purposes of Real Estate and Litigation. Councilwoman Phillips seconded the motion. Motion carried. Yes 4, No 0, Abstained 0.

Respectfully submitted.

---

Ryan P. Shirley, Mayor

Attest:

---

Karen Norred, City Clerk  
(Seal)

**City of Holly Springs  
City Council Special Called Meeting Minutes  
April 27, 2026  
6:00 PM**

**Elected Officials Present:** Mayor Ryan Shirley, Mayor Pro Tem Michael Zenchuk II, Councilwoman Dee Phillips, Councilman Kyle Whitaker, and Councilman Kevin Moore.

**Elected Officials Not Present:** Councilman Jeff Wilbur.

Staff Present: City Attorney Robert M. "Bobby" Dyer, City Manager Robert H. Logan, Assistant City Manager/City Clerk Karen Norred, and Chief Tommy Keheley.

**I. CALL TO ORDER**

Mayor Shirley called the City Council Special Meeting to order.

**II. PLEDGE OF ALLEGIANCE**

Mayor Shirley led the Pledge of Allegiance.

**III. INVOCATION**

Mayor Pro Tem Zenchuk gave the invocation.

**IV. NEW BUSINESS**

- A. Resolution to open a Transportation Special Purpose Local Option Sales Tax (TSPLOST) checking account at South State Bank.

Mayor Pro Tem Zenchuk made a motion to approve Item A. Councilman Moore seconded the motion. Motion carried. Yes 4, No 0, Abstained 0.

**V. ADJOURNMENT**

Mayor Pro Tem Zenchuk made a motion to adjourn the meeting and move into executive session for the purposes of Real Estate and Litigation. Councilwoman Phillips seconded the motion. Motion carried. Yes 4, No 0, Abstained 0.

**VI. EXECUTIVE SESSION**

- A. Real Estate

Respectfully submitted.

Attest:

---

Ryan P. Shirley, Mayor

---

Karen Norred, City Clerk  
(Seal)

# ITEM REPORT

**AGENDA ITEM NUMBER: VIII.A.**



**FROM:** Robert H. Logan, City Manager

**MEETING DATE:** May 21, 2026

**AGENDA ITEM:** Memorandum of Understanding between the City of Holly Springs, Georgia and First Baptist Church of Woodstock to establish a collaborative partnership to support the development and implementation of a transitional supportive housing community for homeless single mothers and their children in our community and ratify the Mayor's signature.

---

## **EXECUTIVE SUMMARY:**

First Baptist Church of Woodstock plans to build a small town home development in our community to provide safe, stable housing combined with comprehensive support services that promote long-term self-sufficiency and reduce homelessness in Cherokee County. The initiative will support the development and implementation of a transitional supportive housing community for homeless single mothers and their children. Pursuant to the Memorandum of Understanding (MOU) between the City of Holly Springs (City) and First Baptist Church of Woodstock, the City agrees to serve as a collaborative partner in support of the project by: (1) supporting the project's alignment with local housing and community development priorities, (2) facilitating coordination with relevant city departments and services, (3) recognizing the project as a community-supported initiative addressing housing instability, and (4) providing an ongoing partnership and engagement to support the long-term success of the development.

## **IS THIS A BUDGETED ITEM?**

N/A

## **FUNDING SOURCE:**

N/A

## **FISCAL IMPACT:**

N/A

**ATTACHMENTS:**

1. MOU - First Baptist Church of Woodstock

**RECOMMENDATION:**

The staff recommendation is approval of the Memorandum of Understanding.

**CONCURRENCES:**

Finance and Administration.

# Memorandum of Understanding (MOU)

**Between:** First Baptist Church of Woodstock and the City of Holly Springs

## 1. Purpose

This Memorandum of Understanding (MOU) establishes a collaborative partnership between First Baptist Church of Woodstock (“the Church”) and the City of Holly Springs (“the City”) to support the development and implementation of a transitional supportive housing community for homeless single mothers and their children.

This initiative is designed to provide safe, stable housing combined with comprehensive support services that promote long-term self-sufficiency and reduce homelessness within Cherokee County.

## 2. Project Overview

The project consists of the development of a residential community located in Holly Springs, Georgia, which will include:

- Construction of townhomes to house program participants
- Conversion of an existing structure into a training and administrative center
- Utilization of an on-site daycare facility to provide childcare and workforce support

Participants will reside in the program for approximately **18–24 months**, during which they will receive structured services in partnership with Serenade Heights, including:

- Workforce development and employment placement
- Financial literacy and budgeting
- Parenting education and life-skills training
- Case management and accountability

## 3. Roles and Responsibilities

### First Baptist Church of Woodstock

The Church will serve as the lead entity responsible for:

- Acquisition, ownership, and development of the property
- Securing and managing project funding
- Overseeing construction, site development, and project completion

- Providing operational oversight of the housing program
- Coordinating with Serenade Heights to deliver program services
- Ensuring compliance with applicable grant requirements and reporting standards

### **City of Holly Springs**

The City agrees to serve as a collaborative partner in support of the project by:

- Supporting the project's alignment with local housing and community development priorities
- Facilitating coordination, where appropriate, with relevant city departments and services
- Recognizing the project as a community-supported initiative addressing housing instability
- Providing ongoing partnership and engagement to support the long-term success of the development

*Nothing in this MOU obligates the City to provide direct financial contributions unless otherwise agreed in writing.*

### **4. Collaborative Partnership**

Both parties agree to work cooperatively to:

- Support the successful development and implementation of the project
- Maintain open communication regarding project progress and community impact
- Promote efforts that reduce homelessness and improve housing stability within the region

This partnership reflects a shared commitment to addressing the needs of vulnerable families through practical, community-based solutions.

### **5. Term**

This MOU shall become effective upon execution by both parties and shall remain in effect unless modified or terminated by mutual written agreement.

### **6. Non-Binding Agreement**

This MOU is intended to document the mutual understanding and cooperative intent of the parties. It does not create a legally binding financial obligation but reflects a good-faith partnership in support of the project.

**Signatures**

**First Baptist Church of Woodstock**

By: \_\_\_\_\_

Name:

Title:

Date:

**City of Holly Springs**

By:  \_\_\_\_\_  
Name: Ryan Shirley  
Title: mayor  
Date: 5/11/2026

# ITEM REPORT

**AGENDA ITEM NUMBER: VIII.B.**



**FROM:** Robert H. Logan, City Manager

**MEETING DATE:** May 21, 2026

**AGENDA ITEM:** Professional Services Agreement between LJA Engineering, Inc. and the City of Holly Springs, Georgia for engineering and capital project management services, and authorize the Mayor to execute the documents pending approval of the City Attorney.

---

## **EXECUTIVE SUMMARY:**

The City of Holly Springs currently has a professional services agreement with BM&K Construction and Engineering (BM&K) for engineering and capital project management services for a wide variety of infrastructure projects and consulting services. BM&K is now part of LJA Engineering, Inc. (LJA). The City of Holly Springs requested an updated Professional Services Agreement between the City and LJA in April. The revised agreement maintains current hourly rates for all existing projects. New capital projects will be billed at the hourly rates shown in the attached schedule. The three percent (3%) annual escalator will remain in effect in the new agreement.

## **IS THIS A BUDGETED ITEM?**

Yes

## **FUNDING SOURCE:**

General Fund  
SPLOST

## **FISCAL IMPACT:**

Fiscal impact will be based upon hourly rates as shown in the attached Professional Services Agreement.

## **ATTACHMENTS:**

1. City of Holly Springs LJA Rates
2. 2026 LJA Professional Services Agreement - REVISED

**RECOMMENDATION:**

The staff recommendation is approval of the Professional Services Agreement.

**CONCURRENCES:**

Finance and Administration

**LJA Engineering, Inc. Hourly Rates  
Prepared for the City of Holly Springs**

<b>Billing Category</b>	<b>Current Rates</b>	<b>Hourly Rate</b>
Program Manager/Principal	\$109.72	\$175
Senior Project Manager	\$93.85	\$155
Senior Engineer	\$93.85	\$155
Project Engineer	\$84.11	\$105
Project Manager	\$84.11	\$125
Right of Way Director	\$93.85	\$175
Right of Way Project Manager	\$93.85	\$105
Administrative Support	\$37.67	\$60
Appraiser	\$84.11	\$105
Senior Inspector	\$74.36	\$95
Inspector	\$74.36	\$75
Senior Surveyor	N/A	\$125
Project Surveyor	N/A	\$100
Construction Field Project Manager	\$84.11	\$110
Principal Planner	N/A	\$165
Senior Planner	N/A	\$150
Planner	N/A	\$100
Geotechnical Engineer	N/A	\$150
Preconstruction Engineer/Manager	N/A	\$145

- Current Rates will apply to the current active projects until completion:
  - Hickory Road
  - Palm Street Bridge Replacement
  - Holly Springs Parkway Phase 3 CEI
  - Private Development Inspections
  - Storm Water Projects
- Private Development Inspections and Plan Review will follow current schedule
- New Capital and TSPLOST/ SPLOST funded projects will utilize new rate schedule
- Escalator of 3% annually will remain

**PROFESSIONAL SERVICES AGREEMENT  
FOR  
ENGINEERING AND MANAGEMENT SERVICES**

**THIS AGREEMENT** is effective as of this \_\_\_\_ day of \_\_\_\_\_, 2026 (the “Effective Date”), by and between the **CITY OF HOLLY SPRINGS**, a political subdivision of the State of Georgia, acting by and through its governing authority, the City of Holly Springs (“City”), and **LJA ENGINEERING, INC.**, formerly known as BM&K, Inc., (“Consultant”), collectively referred to as the “Parties.” The above Effective Date shall be the date this Agreement is formally and properly approved by the City of Holly Springs.

**WITNESSETH THAT:**

**WHEREAS**, the City desires to retain Consultant to provide certain services generally described as engineering and management services for the; and

**WHEREAS**, the City finds that specialized knowledge, skills, and training are necessary to perform the Work contemplated under this Agreement; and

**WHEREAS**, the Consultant has represented that it is qualified by training and experience to perform the Work; and

**WHEREAS**, the Consultant desires to perform the Work under the terms and conditions set forth in this Agreement; and

**WHEREAS**, the public interest will be served by this Agreement;

**NOW, THEREFORE**, for and in consideration of the mutual promises, the public purposes, and the acknowledgements and agreements contained herein, together with other good and adequate consideration, the sufficiency of which is hereby acknowledged, the Parties hereto do mutually agree as follows:

**I. SCOPE OF SERVICES AND TERMINATION DATE**

**A. Agreement.** The Agreement shall consist of this Agreement and each of the Exhibits hereto, which are incorporated herein by reference, including:

**Exhibit A** – Scope of Work & Hourly Rate Schedule

**Exhibit B** – Contractor Affidavit

**Exhibit C** – Subcontractor Affidavit

**B. The Work.** The Work to be completed under this Agreement (the “Work”) consists of engineering and management services for the City’s infrastructure projects as more particularly described in Exhibit “A,” attached hereto and incorporated herein by reference.

**C. Schedule, Completion Date, and Term of Agreement.** Consultant warrants and represents that it will perform its services in a prompt and timely manner, which shall not impose delays on the progress of the Work. This Agreement shall commence as of the Effective Date first written above, and the Work shall be completed, unless earlier terminated as provided for herein, on or before the five-year anniversary of the Effective Date hereof.

The Parties agree that this Agreement, as required by O.C.G.A. § 36-60-13, shall terminate absolutely and without further obligation on the part of the City on December 31 each fiscal year of the Term, and further, that this Agreement shall automatically renew on January 1 of each subsequent fiscal year absent the City's provision of written notice of non-renewal to Consultant at least five (5) days prior to the end of the then current fiscal year. Title to any supplies, materials, equipment, or other personal property shall remain with the Consultant until fully paid for by the City.

## **II. AMENDMENTS**

**A.** The City reserves the right to amend the Work to be performed under this Agreement by altering, adding to, or deducting from the Work. All such changes shall be incorporated in written amendments executed by both the Consultant and the City. Each amendment shall specify the changes and any necessary adjustment to compensation and completion time. If the Parties cannot reach an agreement on the terms for completing amendment(s) within a reasonable time to avoid delay or other unfavorable impacts as determined by the City in its sole discretion, the City shall have the right to determine reasonable terms, and the Consultant shall proceed with the amendment(s).

## **III. COMPENSATION AND METHOD OF PAYMENT**

**A.** City agrees to pay the Consultant for the Work performed by Consultant upon certification by the City that the Work was actually performed in accordance with the Agreement. Compensation for Work performed shall be paid to the Consultant upon receipt and approval by the City of invoices setting forth in detail the services performed. Invoices shall be submitted on a monthly basis, and such invoices shall reflect charges incurred versus charges budgeted. Any material deviations from the Work described in this Agreement shall be clearly communicated in writing to the City *before charges are incurred* and shall be handled through amendment(s) as described in Section II above. The City shall pay the Consultant within thirty (30) days after approval of the invoice by City staff.

**B.** The total amount paid under this Agreement as compensation for Work performed and reimbursement for costs incurred shall not, in any case, exceed the hourly rates as delineated in the attached Exhibit A (the "Scope of Services & Hourly Rate Schedule"). The compensation for Work performed shall be based upon such hourly rates, and Consultant represents that such rates are sufficient to perform all of the Work set forth in and contemplated by this Agreement.

#### IV. COVENANTS OF CONSULTANT

A. **Expertise of Consultant.** Consultant accepts the relationship of trust and confidence established between it and the City, recognizing that the City's intention and purpose in entering into this Agreement is to engage an entity with the requisite capacity, experience, and professional skill and judgment to provide the Work in pursuit of the timely and competent completion of the Work undertaken by Consultant under this Agreement.

B. **Budgetary Limitations.** Consultant agrees and acknowledges that budgetary limitations are not a justification for breach of sound principals of Consultant's profession and industry. Consultant shall take no calculated risk in the performance of the Work. Specifically, Consultant agrees that, in the event it cannot perform the Work within the budgetary limitations established without disregarding sound principals of Consultant's profession and industry, Consultant will give written notice immediately to the City.

C. **City's Reliance on the Work.** The Consultant acknowledges and agrees that the City does not undertake to approve or pass upon matters of expertise of the Consultant and that, therefore, the City bears no responsibility for Consultant's Work performed under this Agreement. The Consultant acknowledges and agrees that the acceptance of designs, plans, and specifications by the City is limited to the function of determining whether there has been compliance with what is required to be produced under this Agreement. The City will not, and need not, inquire into adequacy, fitness, suitability or correctness of Consultant's performance. Consultant further agrees that no approval of designs, plans, or specifications by any person, body or agency shall relieve Consultant of the responsibility for adequacy, fitness, suitability, and correctness of Consultant's Work under professional and industry standards, or for performing services under this Agreement in accordance with sound and accepted professional and industry principals.

D. **Consultant's Reliance on Submissions by the City.** Consultant must have timely information and input from the City in order to perform the Work required under this Agreement. Consultant is entitled to rely upon information provided by the City, but Consultant shall be required to provide immediate written notice to the City if Consultant knows or reasonably should know that any information provided by the City is erroneous, inconsistent, or otherwise problematic.

E. **Consultant's Representative.** Donald B. Clerici, P.E., or his designee shall be authorized to act on Consultant's behalf with respect to the Work as Consultant's designated representative.

F. **Assignment of Agreement.** The Consultant covenants and agrees not to assign or transfer any interest in, nor delegate any duties of this Agreement, without the prior express written consent of the City. As to any approved subcontractors, the Consultant shall be solely responsible for reimbursing them, and the City shall have no obligation to them.

G. **Responsibility of Consultant and Indemnification of City.** The Consultant covenants and agrees to take and assume all responsibility for the Work rendered in connection

with this Agreement. The Consultant shall bear all losses and damages directly or indirectly resulting to it and/or the City on account of the performance or character of the Work rendered pursuant to this Agreement. Consultant shall defend, indemnify and hold harmless the City, its officers, boards, commissions, elected and appointed officials, employees, servants, volunteers and agents (hereinafter referred to as “City Parties”) from and against any and all claims, injuries, suits, actions, judgments, damages, losses, costs, expenses and liability of any kind whatsoever, including but not limited to, attorney’s fees and costs of defense, (hereinafter “Liabilities”) which may be the result of willful, negligent or tortious conduct arising out of the Work, performance of contracted services, or operations by the Consultant, any subcontractor, anyone directly or indirectly employed by the Consultant or subcontractor or anyone for whose acts the Consultant or subcontractor may be liable, regardless of whether or not the negligent act is caused in part by a party indemnified hereunder. This indemnity obligation does not include Liabilities caused by or resulting from the sole negligence of the City or City Parties. Such obligation shall not be construed to negate, abridge, or otherwise reduce any other right or obligation of indemnity which would otherwise exist as to any party or person described in this provision. In any and all claims against the City or City Parties, by any employee of the Consultant, any subcontractor, anyone directly or indirectly employed by the Consultant or subcontractor or anyone for whose acts the Consultant or subcontractor may be liable, the indemnification obligation set forth in this provision shall not be limited in any way by any limitation on the amount or type of damages, compensation or benefits payable by or for the Consultant or any subcontractor under workers’ or workmen’s compensation acts, disability benefit acts or other employee benefit acts. This obligation to indemnify, defend, and hold harmless the City and City Parties shall survive expiration or termination of this Agreement, provided that the claims are based upon or arise out of actions that occurred during the performance of this Agreement.

**H. Independent Contractor.** Consultant hereby covenants and declares that it is engaged in an independent business and agrees to perform the Work as an independent contractor and not as the agent or employee of the City. The Consultant agrees to be solely responsible for its own matters relating to the time and place the services are performed; the instrumentalities, tools, supplies and/or materials necessary to complete the Work; hiring of Consultants, agents or employees to complete the Work; and the payment of employees, including compliance with Social Security, withholding and all other regulations governing such matters. The Consultant agrees to be solely responsible for its own acts and those of its subordinates, employees, and subcontractors during the life of this Agreement. Any provisions of this Agreement that may appear to give the City the right to direct Consultant as to the details of the services to be performed by Consultant or to exercise a measure of control over such services will be deemed to mean that Consultant shall follow the directions of the City with regard to the results of such services only.

**I. Insurance**

(1) Requirements: The Consultant shall have and maintain in full force and effect for the duration of this Agreement, insurance insuring against claims for injuries to persons or damages to property which may arise from or in connection with the performance of the Work by the Consultant, its agents, representatives, employees or subcontractors. All

policies shall be subject to approval by the City Attorney as to form and content. These requirements are subject to amendment or waiver if so approved, by City Council, in writing by the City Manager.

(2) Minimum Limits of Insurance: Consultant shall maintain the following insurance policies with limits no less than:

- (a) Comprehensive General Liability of \$1,000,000 (one million dollars) combined single limit per occurrence for bodily and personal injury, sickness, disease or death, injury to or destruction of property, including loss of use resulting therefrom.
- (b) Comprehensive Automobile Liability (owned, non-owned, hired) of \$1,000,000 (one million dollars) combined single limit per occurrence for bodily and personal injury, sickness, disease or death, injury to or destruction of property, including loss of use resulting therefrom.
- (c) Professional Liability of \$2,000,000 (two million dollars) limit for claims arising out of professional services and caused by the Consultant's errors, omissions, or negligent acts.
- (d) Workers' Compensation limits as required by the State of Georgia and Employers Liability limits of \$1,000,000 (one million dollars) per accident.

(3) Deductibles and Self-Insured Retentions: Any deductibles or self-insured retentions must be declared to and approved by the City Council in writing.

(4) Other Insurance Provisions: The policy is to contain, or be endorsed to contain, the following provisions:

(a) General Liability and Automobile Liability Coverage.

(i) The City and City Parties are to be covered as insureds as respects: liability arising out of activities performed by or on behalf of the Consultant; products and completed operations of the Consultant; premises owned, leased, or used by the Consultant; automobiles owned, leased, hired, or borrowed by the Consultant. The coverage shall contain no special limitations on the scope of protection afforded to the City or City Parties.

(ii) The Consultant's insurance coverage shall be primary noncontributing insurance as respects to any other insurance or self-insurance available to the City or City Parties. Any insurance or self-insurance maintained by the City or City Parties shall be in excess of the Consultant's insurance and shall not contribute with

it.

- (iii) Any failure to comply with reporting provisions of the policies shall not affect coverage provided to the City and City Parties.
- (iv) Coverage shall state that the Consultant's insurance shall apply separately to each insured against whom claim is made or suit is brought.
- (v) Coverage shall be provided on a "pay on behalf" basis, with defense costs payable in addition to policy limits. There shall be no cross liability exclusion.
- (vi) The insurer shall agree to waive all rights of subrogation against the City and City Parties for losses arising from work performed by the Consultant for the City.

(b) Workers' Compensation Coverage. The insurer providing Workers' Compensation Coverage will agree to waive all rights of subrogation against the City and City Parties for losses arising from work performed by the Consultant for the City.

(c) All Coverages.

- (i) Each insurance policy required by this clause shall be endorsed to state that coverage shall not be suspended, voided, canceled, reduced in coverage or in limits except after thirty (30) days prior written notice by certified mail, return receipt requested, has been given to the City.
- (ii) Policies shall have concurrent starting and ending dates.

(5) Acceptability of Insurers: Insurance is to be placed with insurers with an A.M. Best's rating of no less than A:VII.

(6) Verification of Coverage: Consultant shall furnish the City with certificates of insurance and endorsements to the policies evidencing coverage required by this Article prior to the start of work. The certificate of insurance and endorsements shall be on a form utilized by Consultant's insurer in its normal course of business and shall be received and approved by the City prior to execution of this Agreement by the City. The City reserves the right to require complete, certified copies of all required insurance policies at any time. The Consultant shall provide proof that any expiring coverage has been renewed or replaced at least two (2) weeks prior to the expiration of the coverage.

(7) Subcontractors: Consultant shall include all subcontractors as insureds under its policies or shall furnish separate certificates and endorsements for each subcontractor. All

coverage for subcontractors shall be subject to all of the requirements stated in this Agreement, including but not limited to naming the parties as additional insureds.

(8) Claims-Made Policies: Consultant shall extend any claims-made insurance policy for at least six (6) years after termination or final payment under the Agreement, whichever is later.

(9) City as Additional Insured and Loss Payee: The City shall be named as an additional insured and loss payee on all policies required by this Agreement, except the City need not be named as an additional insured and loss payee on any Professional Liability policy or Workers' Compensation policy.

**J. Records, Reports and Audits**

(1) Records:

(a) Records shall be established and maintained by the Consultant in accordance with requirements prescribed by the City with respect to all matters covered by this Agreement. Except as otherwise authorized, such records shall be maintained for a period of three years from the date that final payment is made under this Agreement. Furthermore, records that are the subject of audit findings shall be retained for three years or until such audit findings have been resolved, whichever is later.

(b) All costs shall be supported by properly executed payrolls, time records, invoices, contracts, or vouchers, or other official documentation evidencing in proper detail the nature and propriety of the charges. All checks, payrolls, invoices, contracts, vouchers, orders or other accounting documents pertaining in whole or in part to this Agreement shall be clearly identified and readily accessible.

(2) Reports and Information. Upon request, the Consultant shall furnish to the City any and all statements, records, reports, data and information related to matters covered by this Agreement in the form requested by the City.

(3) Audits and Inspections. At any time during normal business hours and as often as the City may deem necessary, there shall be made available to the City for examination all records with respect to all matters covered by this Agreement. The Consultant will permit the City to audit, examine, and make excerpts or transcripts from such records, and to audit all contracts, invoices, materials, payrolls, records of personnel, conditions of employment and or data relating to all matters covered by this Agreement.

**K. Conflicts of Interest**. Consultant agrees that it shall not engage in any activity or conduct that would result in a violation of the City of Holly Springs Code of Ethics.

**L. Confidentiality.** Consultant acknowledges that it may receive confidential information of the City and that it will protect the confidentiality of any such confidential information and will require any of its subcontractors, consultants, and/or staff to likewise protect such confidential information. The Consultant agrees that confidential information it receives or such reports, information, opinions or conclusions that Consultant creates under this Agreement shall not be made available to, or discussed with, any individual or organization, including the news media, without prior written approval of the City. The Consultant shall exercise reasonable precautions to prevent the unauthorized disclosure and use of City information whether specifically deemed confidential or not.

Consultant acknowledges that the City's disclosure of documentation is governed by Georgia's Open Record's Act, and Consultant further acknowledges that if Consultant submits records containing trade secret information, and if Consultant wishes to keep such records confidential, Consultant must submit and attach to such records an affidavit affirmatively declaring that specific information in the records constitutes trade secrets pursuant to Article 27 of Chapter 1 of Title 10, and the Parties shall follow the requirements of O.C.G.A. § 50-18-72(a)(34) related thereto.

**M. Licenses, Certifications and Permits.** The Consultant covenants and declares that it has obtained all diplomas, certificates, licenses, permits or the like required of the Consultant by any and all national, state, regional, City, local boards, agencies, commissions, committees or other regulatory bodies in order to perform the Work contracted for under this Agreement. All work performed by Consultant under this Agreement shall be in accordance with applicable legal requirements and shall meet the standard of quality ordinarily expected of competent professionals.

**N. Key Personnel.** All of the positions identified in Exhibit "A" are necessary for the successful completion of the Work due to their unique expertise and depth and breadth of experience. There shall be no change in Consultant's Project Manager or members of the project team, as listed in Exhibit "A," without written approval of the City. Consultant recognizes that the composition of this team was instrumental in the City's decision to award the work to Consultant and that compelling reasons for substituting these individuals must be demonstrated for the City's consent to be granted. Any substitutes shall be persons of comparable or superior expertise and experience. Failure to comply with the provisions of this section shall constitute a material breach of Consultant's obligations under this Agreement and shall be grounds for termination. Consultant shall not subcontract with any third party for the performance of any portion of the Work without the prior written consent of the City. Consultant shall be solely responsible for any such subcontractors in terms of performance and compensation.

**O. Authority to Contract.** The Consultant covenants and declares that it has obtained all necessary approvals of its board of directors, stockholders, general partners, limited partners or similar authorities to simultaneously execute and bind Consultant to the terms of this Agreement, if applicable.

**P. Ownership of Work.** All reports, designs, drawings, plans, specifications,

schedules, work product and other materials prepared or in the process of being prepared for the Work to be performed by the Consultant (“Materials”) shall be the property of the City, and the City shall be entitled to full access and copies of all such Materials. Any such Materials remaining in the hands of the Consultant or subcontractor upon completion or termination of the Work shall be delivered immediately to the City. The Consultant assumes all risk of loss, damage or destruction of or to such Materials. If any Materials are lost, damaged or destroyed before final delivery to the City, the Consultant shall replace them at its own expense. Any and all copyrightable subject matter in all Materials is hereby assigned to the City, and the Consultant agrees to execute any additional documents that may be necessary to evidence such assignment.

**Q. Nondiscrimination.** In accordance with Title VI of the Civil Rights Act, as amended, 42 U.S.C. § 2000d, section 303 of the Age Discrimination Act of 1975, as amended, 42 U.S.C. § 6102, section 202 of the Americans with Disabilities Act of 1990, 42 U.S.C. § 12132, and all other provisions of Federal law, the Consultant agrees that, during performance of this Agreement, Consultant, for itself, its assignees and successors in interest, will not discriminate against any employee or applicant for employment, any subcontractor, or any supplier because of race, color, creed, national origin, gender, age or disability. In addition, Consultant agrees to comply with all applicable implementing regulations and shall include the provisions of this Section IV(R) in every subcontract for services contemplated under this Agreement.

## **V. COVENANTS OF THE CITY**

**A. City’s Representative. Robert Logan, City Manager,** shall be authorized to act on the City’s behalf with respect to the Work as the City’s designated representative, provided that any amendments to the Work or the terms of this Agreement must be approved as provided in Section II above.

## **VI. TERMINATION**

**A.** The City shall have the right to terminate this Agreement for convenience by providing written notice thereof at least thirty (30) calendar days in advance of the termination date. The Consultant shall have no right to terminate this Agreement prior to completion of the Work, except in the event of the City’s failure to pay the Consultant within thirty (30) days of Consultant providing the City with notice of a delinquent payment and an opportunity to cure.

**B.** Upon termination, City shall provide for payment to the Consultant for services rendered and expenses incurred prior to the termination date.

**C.** Upon termination, the Consultant shall: (1) promptly discontinue all services affected, unless the notice directs otherwise; and (2) promptly deliver to the City all data, drawings, reports, summaries, and such other information and materials as may have been generated or used by the Consultant in performing this Agreement, whether completed or in process, in the form specified by the City.

**D.** The rights and remedies of the City and the Consultant provided in this Article are in addition to any other rights and remedies provided under this Agreement or at law or in equity.

## **VII. NO PERSONAL LIABILITY**

Nothing herein shall be construed as creating any individual or personal liability on the part of any City Party. No City Party shall be personally liable to the Consultant or any successor in interest in the event of any default or breach by the City or for any amount which may become due to the Consultant or successor or on any obligation under the terms of this Agreement. Likewise, Consultant's performance of services under this Agreement shall not subject Consultant's individual employees, officers or directors to any personal liability. The Parties agree that their sole and exclusive remedy, claim, demand or suit shall be directed and/or asserted only against Consultant or the City, respectively, and not against any employee, officer, director, or elected or appointed official.

## **VIII. ENTIRE AGREEMENT**

This Agreement constitutes the entire agreement between the Parties and supersedes any and all other agreements, either oral or in writing, between the Parties with respect to the subject matter of this Agreement. No other agreement, statement or promise relating to the subject matter of this Agreement not contained in this Agreement shall be valid or binding. This Agreement may be modified or amended only by a written document signed by representatives of both Parties with appropriate authorization.

## **IX. SUCCESSORS AND ASSIGNS**

Subject to the provision of this Agreement regarding assignment, this Agreement shall be binding on the heirs, executors, administrators, successors and assigns of the respective Parties, provided that no party may assign this Agreement without prior written approval of the other party.

## **X. APPLICABLE LAW**

If any action at law or in equity is brought to enforce or interpret the provisions of this Agreement, the rules, regulations, statutes and laws of the State of Georgia will control. Any action or suit related to this Agreement shall be brought in the Superior Court of Cherokee County, Georgia.

The Parties, as a condition precedent to commencing litigation (other than for the non-payment of Consultant's fees), shall endeavor to resolve their claims by mediation which, shall be in accordance with the Construction Industry Mediation Rules of the American Arbitration Association currently in effect. Request for mediation shall be filed in writing with the other party to the contract and with the American Arbitration Association.

## **XI. CAPTIONS AND SEVERABILITY**

The caption or headnote on articles or sections of this Agreement are intended for convenience and reference purposes only and in no way define, limit or describe the scope or intent thereof, or of this Agreement nor in any way affect this Agreement. Should any article(s) or section(s), or any part thereof, later be deemed unenforceable by a court of competent jurisdiction, the offending portion of the Agreement should be severed, and the remainder of this Agreement shall remain in full force and effect to the extent possible.

## **XII. BUSINESS LICENSE**

Consultant must provide a current business license prior to commencement of the services to be provided hereunder. If a current business license is not available, Consultant shall apply to the City for a business license, pay the applicable business license fee, maintain said business license during the term of this Agreement.

## **XIII. NOTICES**

**A. Communications Relating to Day-to-Day Activities.** All communications relating to the day-to-day activities of the Work shall be exchanged between Rober H. Logan, City Manager or his designee, for the City and Donald B. Clerici, Vice President or his designee for the Consultant.

**B. Official Notices.** All other notices, requests, demands, writings, or correspondence, as required by this Agreement, shall be in writing and shall be deemed received, and shall be effective, when: (1) personally delivered, or (2) on the third day after the postmark date when mailed by certified mail, postage prepaid, return receipt requested, or (3) upon actual delivery when sent via national overnight commercial carrier to the Parties at the addresses given below, or at a substitute address previously furnished to the other Parties by written notice in accordance herewith:

**NOTICE TO THE CITY** shall be sent to:

Robert Logan, City Manager  
City of Holly Springs  
3237 Holly Springs  
Holly Springs, GA 30115

**NOTICE TO THE CONSULTANT** shall be sent to:

Donald B. Clerici, Vice President  
LJA ENGINEERING, INC.  
89 E Athens Street  
Winder, Georgia 30680

Future changes in address shall be effective only upon written notice being given by the City Manager to Consultant or by Consultant to City Manager via one of the delivery methods described in this Section.

#### **XIV. WAIVER OF AGREEMENT**

No failure by the City to enforce any right or power granted under this Agreement, or to insist upon strict compliance by Consultant with this Agreement, and no custom or practice of the City at variance with the terms and conditions of this Agreement shall constitute a general waiver of any future breach or default or affect the City's right to demand exact and strict compliance by Consultant with the terms and conditions of this Agreement.

#### **XV. NO THIRD-PARTY RIGHTS**

This Agreement shall be exclusively for the benefit of the Parties and shall not provide any third parties with any remedy, claim, liability, reimbursement, cause of action or other right.

#### **XVI. SOVEREIGN IMMUNITY**

Nothing contained in this Agreement shall be construed to be a waiver of the City's sovereign immunity or any individual's qualified good faith or official immunities.

#### **XVII. FORCE MAJEURE**

Neither the City nor Consultant shall be liable for their respective non-negligent or non-willful failure to perform or shall be deemed in default with respect to the failure to perform (or cure a failure to perform) any of their respective duties or obligations under this Agreement or for any delay in such performance due to: (a) any cause beyond their respective reasonable control; (b) any act of God; (c) any change in applicable governmental rules or regulations rendering the performance of any portion of this Agreement legally impossible; (d) earthquake, fire, explosion or flood; (e) strike or labor dispute, excluding strikes or labor disputes by employees and/or agents of Consultant; (f) delay or failure to act by any governmental or military authority; or (g) any war, hostility, embargo, sabotage, civil disturbance, riot, insurrection or invasion. In such event, the time for performance shall be extended by an amount of time equal to the period of delay caused by such acts, and all other obligations shall remain intact.

(remainder of this page intentionally left blank)

(signature page follows)

**IN WITNESS WHEREOF** the City and the Consultant have executed this Agreement effective as of the date first written hereinabove.

**CONSULTANT:**

**LJA ENGINEERING, INC.**

By: \_\_\_\_\_  
Donald B. Clerici, Vice President

[CORPORATE SEAL]

Attest:

\_\_\_\_\_

**CITY OF HOLLY SPRINGS, GEORGIA**

By: \_\_\_\_\_  
Ryan P. Shirley, Mayor

[CITY SEAL]

Attest:

\_\_\_\_\_  
Karen Norred, City Clerk

Approved as to form:

\_\_\_\_\_  
City Attorney

## EXHIBIT A

### SCOPE OF SERVICES & HOURLY RATE SCHEDULE

#### I. Scope of Services

This statement of work describes and defines the Services which are required for construction management, engineering, and program management, and contract administration for various design and construction projects in Holly Springs. The parties acknowledge that the **Consultant** is an independent contractor and that the **City** does not control the time, manner and method of the accomplishment of the work or project.

**Consultant** is solely responsible for any and all taxes.

##### A. General

- 1) The **Consultant** shall cooperate fully with the GDOT , Federal Highway Administration, consultants on adjacent projects, consultants for final plans, municipalities and local government officials, utility companies, railroads, and others, as may be directed by the **City**. Such cooperation shall include attendance at meetings, discussions, and hearings, as may be requested by the **City**, furnishing plans and other data produced in the course of work on the Project, as may be requested from time to time by the **City** to effect such cooperation and compliance with all directives issued by the **City**.  
It is understood and agreed that City Staff may have access to the work and be furnished information as directed.
- 2) The **Consultant** shall be responsible for construction inspection, Construction management, and assisting the **City** with engineering, transportation planning, and guidance on any issues deemed necessary by the Manager and the staff.
- 3) The **Consultant** shall be responsible for assigned construction administrative functions as defined in this Scope of Services and referenced manuals and procedures. The **Consultant** will make effective use of Senior Project Engineer/Manager's time and supplement activities of administrative assistance and Senior Inspector/technician for duties that can be delegated. This will make for effective use of time and resources and reduce the overall cost to the projects.
- 4) The **Consultant** shall utilize effective control procedures to determine and to ensure that the contractor's construction of this project is performed in reasonably close conformity with the plans, specifications, and contract provisions.
- 5) The **Consultant** shall be responsible for providing administrative assistance to support his operations and duties. Also, additional staff and inspectors may be required and compensation for each shall be per the approved rate schedule. Additional staff may be provided by the **City**. However, the consultant should

receive prior approval from the manager prior to using additional staff. Additional staff may only be used to support the responsibilities assigned under the Agreement and ensure they are effectively carried out. The **Consultant** will consult with the City Manager or designee prior to using any employee of the **Consultant** on site and who might interact with other **City** employees.

- 6) All Services shall be performed in accordance with the established standard procedures and practices of the **City**. Prior to furnishing any Services, the **Consultant** shall be familiar with those departmental standard procedures and practices.
- 7) The **Consultant** shall provide 1-Senior Project Manager who shall, in addition to the routine duties described herein, serve as the on-site Liaison between Developers, Contractors, Design Firms, GDOT, Other Departments and the **City**. The on-site Liaisons shall have responsibility for administering all of the Consultant Contracts associated with his duties and for coordinating the assignment of additional staff with the City Manager.
- 8) The **Consultant** shall maintain close coordination with the **City** in order to minimize the number of personnel needed during time of reduced activity.

B. Work Activities-Private Development and Capital Projects

- 1) It shall be the responsibility of the **Consultant** to provide Services to ensure that the projects are planned, designed, and constructed by the Developer/Contractor/Design Consultant in reasonably close conformity with the plans, City specifications and other contract provisions.
- 2) The **Consultant** shall work under the general guidance and direction of the City Manager or as assigned. The **Consultant** shall make normal and routine project decisions consistent with the design and construction contract documents with consideration of the City's policies, procedures, and general guidance provided by the **City**. If there is a conflict with the construction contract and the City's policies, procedures, and general guidance, the City Manager or designee shall be consulted for further guidance.
- 3) The **Consultant** shall advise the City Manager of any omissions, substitution, defects and deficiencies noted in the work of the Contractor and any corrective action taken. The Services provided by the **Consultant** shall, in no way, relieve the Contractor/Designer of responsibility for the satisfactory performance of the construction/design contracts.

- 4) The **Consultant** shall make and record such measurements as are necessary to calculate and document quantities for pay items, except for measurement of earthwork quantities and activities that require the services of a survey crew.
- 5) The **Consultant** shall provide Services to monitor the Contractor's on-site construction operation and to inspect all materials incorporated into the work as necessary to determine and to ensure that the quality of the Contractor's workmanship and materials is such that the project will be completed in reasonably close conformance with the plans, specifications, and other contract provisions. The **Consultant** shall keep detailed, accurate records of the Contractor's daily operations and significant events that affect the work. **Consultant** shall enforce all aspects of every design or construction contract. The purpose is to be the "watchdog" for the **City** and to assure them their instructions are carried out for all activities.
- 6) The **Consultant** shall inspect traffic control devices and monitor traffic operations during the normal course of other inspection duties. Additional periodic traffic control inspections and reports shall be made in accordance with the GDOT's policy.
- 7) The **Consultant** shall perform or arrange for nominal field sampling and testing of component materials and completed work items to determine and to ensure the materials and workmanship incorporated into the project are in reasonably close conformance with the plans, specifications, and other contract provisions. Most sampling and testing will be performed by the GDOT's Office of Materials and Research and or other testing consultants. The **Consultant** shall perform only on-site sampling and testing of concrete (air, slump and cylinders) and temperature measurement of asphalt and other items deemed necessary. Some items may require a sub-consultant to perform some activities.
- 8) The **Consultant** shall attend Council Meetings as needed and be available at such times to answer questions or inquiries from the Council.
- 9) The **Consultant** shall maintain on a daily basis a complete and accurate record of all activities relating to the project and a record of all work completed by the Designer/Contractor, including quantities of pay items in conformity with the accepted policies and procedures.
- 10) The **Consultant** shall prepare inspector's daily reports of the Contractor's and Developer's operations.

- 11) The **Consultant** shall maintain records of all sampling and testing accomplished and analyze such records to determine and to ensure acceptability of materials and completed work items.
- 12) The **Consultant** shall analyze changes to the plans, specifications, or other contract provisions and extra work items which appear to be necessary and shall communicate any apparent change to the City Manager or designee. When it is determined that extra work is necessary, the Senior Project Manager/Engineer will initiate any contract change necessary to cause the Contractor/Designer to perform the extra work.
- 13) In the event that the Contractor/Designer gives notice in writing that it is or will be entitled to additional compensation, the **Consultant** shall maintain records of the cost involved in such work in accordance with **City** policy.
- 14) The **Consultant** shall monitor each construction operation to the extent necessary to determine whether construction activities violate the requirements of any permits contained in the contract. The **Consultant** shall notify the Contractor or Developer of any violations or potential violations that require his immediate resolution to the problem. Permit violations must be reported to the City Manager or designee immediately.
- 15) The **Consultant** shall present all records and documentation prepared in the course of project administration to the City Manager or designee at the conclusion of the **Consultant's** assignment to that project. All such records and documentation are the property of the **City**.

**EXHIBIT B**

**STATE OF GEORGIA  
CITY OF HOLLY SPRINGS**

**CONTRACTOR AFFIDAVIT AND AGREEMENT**

By executing this affidavit, the undersigned contractor verifies its compliance with O.C.G.A. § 13-10-91, stating affirmatively that the individual, firm, or corporation which is engaged in the physical performance of services on behalf of the **City of Holly Springs, Georgia**, has registered with, is authorized to use and uses the federal work authorization program commonly known as E-Verify, or any subsequent replacement program, in accordance with the applicable provisions and deadlines established in O.C.G.A. § 13-10-91. Furthermore, the undersigned contractor will continue to use the federal work authorization program throughout the contract period and the undersigned contractor will contract for the physical performance of services in satisfaction of such contract only with subcontractors who present an affidavit to the contractor with the information required by O.C.G.A. § 13-10-91(b).

Contractor hereby attests that its federal work authorization user identification number and date of authorization are as follows:

\_\_\_\_\_  
Federal Work Authorization User Identification  
Number

\_\_\_\_\_  
Date of Authorization

LJA ENGINEERING, INC.  
Name of Contractor

\_\_\_\_\_  
Address of Contractor

\_\_\_\_\_  
Name of Project

CITY OF HOLLY SPRINGS, GEORGIA  
Name of Public Employer

I hereby declare under penalty of perjury that the foregoing is true and correct.

Executed on \_\_\_\_\_, \_\_, 2026, in \_\_\_\_\_ (city),  
\_\_\_\_\_ (state).

\_\_\_\_\_  
Signature of Authorized Officer or Agent

\_\_\_\_\_  
Printed Name and Title of Authorized Officer or  
Agent

SUBSCRIBED AND SWORN BEFORE ME ON  
THIS THE \_\_\_\_\_ DAY OF \_\_\_\_\_, 2026.

\_\_\_\_\_  
NOTARY PUBLIC

My Commission Expires: \_\_\_\_\_

[NOTARY SEAL]

**EXHIBIT "C"**

**STATE OF GEORGIA  
CITY OF HOLLY SPRINGS**

**SUBCONTRACTOR AFFIDAVIT**

By executing this affidavit, the undersigned subcontractor verifies its compliance with O.C.G.A. § 13-10-91, stating affirmatively that the individual, firm or corporation which is engaged in the physical performance of services under a contract with **LJA ENGINEERING, INC.**, on behalf of City of Holly Springs has registered with, is authorized to use and uses the federal work authorization program commonly known as E-Verify, or any subsequent replacement program, in accordance with the applicable provisions and deadlines established in O.C.G.A. § 13-10-91. Furthermore, the undersigned subcontractor will continue to use the federal work authorization program throughout the contract period, and the undersigned subcontractor will contract for the physical performance of services in satisfaction of such contract only with sub-subcontractors who present an affidavit to the subcontractor with the information required by O.C.G.A. § 13-10-91(b). Additionally, the undersigned subcontractor will forward notice of the receipt of an affidavit from a sub-subcontractor to the contractor within five (5) business days of receipt. If the undersigned subcontractor receives notice that a sub-subcontractor has received an affidavit from any other contracted sub-subcontractor, the undersigned subcontractor must forward, within five (5) business days of receipt, a copy of the notice to the contractor.

Subcontractor hereby attests that its federal work authorization user identification number and date of authorization are as follows:

\_\_\_\_\_  
Federal Work Authorization User Identification  
Number

\_\_\_\_\_  
Date of Authorization

\_\_\_\_\_  
Name of Subcontractor

\_\_\_\_\_  
Address of Subcontractor

\_\_\_\_\_  
Name of Project

CITY OF HOLLY SPRINGS, GEORGIA

Name of Public Employer

I hereby declare under penalty of perjury that the foregoing is true and correct.

Executed on \_\_\_\_\_, \_\_, 2026\_ in \_\_\_\_\_ (city),  
\_\_\_\_\_ (state).

\_\_\_\_\_  
Signature of Authorized Officer or Agent

\_\_\_\_\_  
Printed Name and Title of Authorized Officer or Agent

SUBSCRIBED AND SWORN BEFORE ME  
ON THIS THE \_\_\_\_\_ DAY OF \_\_\_\_\_, 2026.

\_\_\_\_\_  
NOTARY PUBLIC

My Commission Expires: \_\_\_\_\_

[NOTARY SEAL]

# ITEM REPORT

**AGENDA ITEM NUMBER: VIII.C.**



**FROM:** Robert H. Logan, City Manager

**MEETING DATE:** May 21, 2026

**AGENDA ITEM:** A resolution of the City of Holly Springs, Georgia to amend the Municipal Services Master Fee Schedule.

---

## **EXECUTIVE SUMMARY:**

A resolution of the City of Holly Springs, Georgia to amend the Municipal Services Master Fee Schedule.

## **FISCAL IMPACT:**

Replace this text with information including total cost, whether or not this is a budgeted expenditure and what budget line should be charged.

## **ATTACHMENTS:**

1. RES-16-2026 Master Fee Schedule Amendment

## **RECOMMENDATION:**

The staff recommendation is approval of the resolution.

## **CONCURRENCES:**

City Manager

**A RESOLUTION OF THE MAYOR AND CITY COUNCIL OF THE CITY OF HOLLY SPRINGS, GEORGIA, TO AMEND THE ADOPTED MUNICIPAL SERVICES MASTER FEE SCHEDULE; TO PROVIDE FOR THE HEALTH, SAFETY, AND WELFARE OF THE GENERAL PUBLIC; TO ESTABLISH THE EFFECTIVE DATE; AND FOR OTHER PURPOSES**

**WHEREAS**, the Mayor and City Council of the City of Holly Springs, Georgia, seek to provide for the health, safety, and welfare of the general public; and

**WHEREAS**, the Mayor and City Council of the City of Holly Springs, Georgia amend the fee schedule from time to time; and

**NOW, THEREFORE, IT IS HEREBY RESOLVED**, that the Mayor and City Council of the City of Holly Springs, Georgia, do hereby adopt the amended Municipal Services Master Fee Schedule as attached hereto as Exhibit "A".

**IT IS HEREBY FURTHER RESOLVED**, by the Mayor and City Council of the City of Holly Springs, Georgia, that the amended Municipal Services Master Fee Schedule attached hereto as Exhibit "A," shall be effective immediately.

This Resolution is adopted this 21<sup>st</sup> day of May 2026.

CITY OF HOLLY SPRINGS

---

Ryan P. Shirley, Mayor

Attest:

---

Karen Norred, City Clerk  
(Seal)

Amend the following:

Exhibit "A"

Local Legal Code	Category	Local Violation Description	Fee Name	Base Fee	Fine Amount
5.4-11A	City Ordinance	CBD, Hemp, THC and/or Tobacco Specialty Store			Fine set by the Judge



# ITEM REPORT

**AGENDA ITEM NUMBER: VIII.D.**

**FROM:** Robert H. Logan, City Manager

**MEETING DATE:** May 21, 2026

**AGENDA ITEM:** To Amend the Information Technology Technician Job Description.

---

**EXECUTIVE SUMMARY:**

To amend the Information Technology Technician Job Description.

**IS THIS A BUDGETED ITEM?**

Yes

**FUNDING SOURCE:**

General Fund

**FISCAL IMPACT:**

The salary range is from \$25.95 to \$39.48 per hour.

**ATTACHMENTS:**

1. IT02- Information Technology Technician

**RECOMMENDATION:**

City Manager, Assistant City Manager/City Clerk

**CONCURRENCES:**

The staff recommendation is approval of the amended job description.



# CITY OF HOLLY SPRINGS

## JOB DESCRIPTION

### A. IDENTIFICATION INFORMATION

1. **Job Title: Information Technology Technician**
2. **Department: ~~Police~~Finance and Administration**  
**Division: ~~Administration~~Information Technology**
3. \_\_\_\_\_ **FLSA Classification: Non-Exempt**  
**Pay Grade: 1416**

### B. INTRODUCTORY STATEMENT

This position is responsible for coordinating and maintaining the overall computer systems and wireless communication equipment within the ~~department~~city. Work involves maintaining the integrity of data, computer systems, and records, maintaining computer hardware, printers, and troubleshooting and repairing systems.

### C. ESSENTIAL JOB FUNCTIONS

1. ~~Assists in the maintenance of~~Maintains the integrity of all data centers, wireless communication equipment, computer systems operations, electronic and optical books, and records of the department.
2. Maintains the operations of terminals, remote and local printers, city-issued computers, and software.
3. Maintains records and logs of trouble calls that can be used as a reference tool in the future or similar calls.
4. Identifies brands of software and hardware that may be faulty and identify inadequately trained users.
5. ~~Troubleshoots and reports~~ Reports all networking, connectivity, rights, and permissions concerns.
6. Provides response to user requests for computer-related assistance in an efficient manner.
7. Troubleshoots, configures, monitors, develops, repairs, and replaces equipment.
8. Assists with the disaster recovery process and in implementing the plans for the disaster recovery function.

9. Trains employees to optimize adequate and efficient use of hardware and software programs.

~~10. Assists with administrative duties including maintaining the department's social media outlets.~~

10. Attends City Council and various other meetings to provide IT support.

11. Performs other duties as assigned.

#### **D. JOB FACTOR SPECIFICATIONS**

##### 1. Job Requirements

###### a. Knowledge, Skill, and Ability

1. Knowledge of network administration principles.
2. Knowledge of departmental policies and procedures.
3. Knowledge of IT operating systems and software.
4. Knowledge of budget management principles and policies.
5. Knowledge of IT user support principles.
6. Ability to maintain confidentiality and exercise discretion in performing assigned duties.
7. Skill in establishing and maintaining filing systems.
8. Skill in problem-solving.
9. Skill in prioritizing and planning.
10. Skill in interpersonal relations.
11. Skill in oral and written communication.

##### 2. Responsibility

- a. This position has no supervision over any other employees.

##### 3. Personal Work Relationships

- a. Contacts are typically with coworkers, vendors, contractors, representatives of other

organizations, and the general public.

- b. Contacts are typically to exchange information, resolve problems, and provide services.

#### 4. Physical Effort and Work Environment

- a. The work is typically performed while sitting at a desk or table or while intermittently sitting, standing, walking, bending, crouching, or stooping. The employee frequently lifts light and heavy objects, climbs ladders, uses tools or equipment requiring a high degree of dexterity, and distinguishes between shades of color.
- b. The work is typically performed in an office, stockroom, vehicle, or occasionally outdoors in cold or inclement weather. The employee is exposed to machinery with moving parts.

#### 5. Guidelines

- a. Guidelines include state and federal laws, traffic laws, city ordinances, court rulings, constitutional guidelines, training manuals, and department policies and procedures. These guidelines are generally clear and specific but may require some interpretation in application.

#### 6. Complexity and Scope of Work

- a. The work consists of varied analytical and technical duties. Frequent changes to industry standards contribute to the complexity of the position.
- b. The purpose of this position is to provide support for the city's information technology functions. Successful performance helps ensure the efficiency and effectiveness of city operations.

#### 7. Minimum Qualifications

- a. Knowledge and level of competency commonly associated with the completion of an associate degree in a course of study related to the occupational field, or equivalent work experience
- b. Sufficient experience to understand the basic principles relevant to the major duties of the position, usually associated with the completion of an apprenticeship/internship or having had a similar position for one to two years.
- c. Possession of or ability to readily obtain a valid driver's license issued by the State of Georgia for the type of vehicle or equipment operated.

8. Supervisory Controls

- a. The ~~division Captain~~ Assistant City Manager/City Clerk assigns work in terms of very general instructions. The supervisor spot-checks completed work for compliance with procedures and the nature and propriety of the final results.

**E. APPROVAL SIGNATURES**

**I have read and understand the attached job description for the position of Information Technology Technician with the City of Holly Springs.**

---

Employee (print)

---

Employee (signature) Date

---

Department Head (print)

---

Department Head (signature) Date

---

City Manager (print)

---

City Manager (signature) Date

# ITEM REPORT

**AGENDA ITEM NUMBER: VIII.E.**



**FROM:** Robert H. Logan, City Manager

**MEETING DATE:** May 21, 2026

**AGENDA ITEM:** Proposal dated May 11, 2026, from SuperHero Fire Protection for an above-ground dry stack fire protection system in the Holly Springs Town Center Parking Deck, in an amount not to exceed \$104,850.

---

## **EXECUTIVE SUMMARY:**

The City of Holly Springs received three quotes for an above-ground dry stack fire protection system in the Holly Springs Town Center Parking Deck. We recommend the quote/proposal from SuperHero Fire Protection in an amount not to exceed \$104,850.

## **IS THIS A BUDGETED ITEM?**

Yes

## **FUNDING SOURCE:**

Bond Revenue

## **FISCAL IMPACT:**

\$104,850

## **ATTACHMENTS:**

1. Fire Protection AG Dry Stack Bids

## **RECOMMENDATION:**

The staff recommendation is approval of the quote/proposal from SuperHero Fire Protection.

**CONCURRENCES:**

Finance and Administration

# SUPERHERO FIRE PROTECTION

## Proposal

May 11, 2026  
Page 1 of 4

**To:** Stonecrest Homes  
625 West Crossville Road  
STE 204  
Roswell, GA 30075

**Project:** COHS Parking Deck  
Holly Springs, GA 30115

**Attn:** Ben Lester  
**Phone:** (404) 391-1806  
**Email:** blester@stonecresthomesga.com

**Professional Design:**  
**Drawing Date:**  
**Drawing Numbers:**

We hereby propose to furnish all labor and material necessary to perform the design, fabrication, installation and testing of a above ground dry stand pipe fire protection system for the project listed above. The installation to be in accordance with NFPA 13 standards as specified on page 2 of 4.

The above work to be performed as specified herein and in a substantial workmanlike manner for the total sum of ..... Pricing Breakdown on Page 2 of 3.

**Black Steel \$104,850**

**NOTES:**

1. If any work is performed, that is not specified above, additional charges will apply.
2. Pendant sprinklers to be semi-recessed chrome pendants with chrome escutcheons. Upright sprinklers to be standard brass attached directly to the piping. Cooler/Freezer sprinklers to be chrome with chrome escutcheons.
3. Applicable sales tax has been added to all pricing.
4. All design and permitting fees will be billed prior to start of installation.
5. This price is assuming CAD files will be available for us in preparing the fire sprinkler shop drawings.

Payments to be made as follows: *Per Approved Schedule of Values*

This proposal may be withdrawn by SuperHero Fire Protection, if not accepted within 30 days.

Respectfully Submitted,

\_\_\_\_\_  
Scott Shelton

Signed: \_\_\_\_\_ Date: \_\_\_\_\_

Printed: \_\_\_\_\_ Title: \_\_\_\_\_

**TERMS AND CONDITIONS**

The above-signed accepts this proposal and all of its specifications & terms and conditions as a binding contract subject only to the approval of the credit of the Buyer by SuperHero Fire Protection, which shall not be unreasonably withheld.

# SUPERHERO FIRE PROTECTION

## Fire Sprinkler Specifications

### COHS Parking Deck

May 11, 2026

Page 2 of 3

1 **SCOPE OF WORK:**

This document specifies the scope of work to be completed by **SuperHero Fire Protection (SHFP)** in the designing, fabricating, installing and testing of an approved Above Ground Dry Stack Fire Protection Piping, Fittings, Valves, & Air Compressor System (Underground Piping & FDC Connection related

2 **DESIGN AND APPROVAL:**

The system shall be designed by hydraulic calculations in accordance with NFPA 13. Design drawings and supporting calculations shall be submitted to the local authority for approval. Local approval and appropriate permits shall be attained prior to start of installation.

3 **EQUIPMENT:**

Sprinkler heads to be UL listed and shall be installed in accordance with their listing in respect to spacing, location and position. Each system shall be provided with an approved system control assembly consisting of one control valve, one 4 x 2-1/2 x 2-1/2" fire department connection on the building, one water flow switch and one test / drain assembly. The piping shall consist of UL listed Steel pipe and fittings using the approved method of joining. Methods for hanging, supporting and securing the system piping shall be in accordance with the material listing.

4 **WATER SUPPLY:**

Buyer is to provide an adequate water supply into each building through a minimum of 4" combination service line from the main and stub up one foot above finished floor into a location agreeable to Buyer and SHFP. Buyer is to provide a 4" flanged outlet on the stub in for the system supply. All underground piping is to be installed, tested and flushed in accordance with NFPA 24 prior to connection with the sprinkler system.

5 **FREEZE PROTECTION:**

The owner shall provide and maintain adequate, continuous heat in all areas containing wet fire protection piping, risers, branch lines, valves, backflow preventers, fire pumps, and appurtenances to prevent freezing. For purposes of this agreement, "adequate heat" shall mean maintaining a minimum ambient temperature of 40 degrees fahrenheit at all times.

6 **EXCLUSIONS:**

- 1) Underground piping of any kind, pressure reducing valves, meter or use fees.  
(SHFP to start 1'-0" AFF at 4" supply line inside provided heated fire sprinkler valve room.)
- 2) Painting of pipe.
- 3) Freeze protection of wet fire sprinkler system, heat trace and insulation.
- 4) Electrical wiring of air compressors, tamper switches, flow switches, and electric bells.
- 5) Access panels, soffits or fur-downs that may be needed to install piping or sprinkler heads.
- 6) Relocation of lines or mains for other trades.
- 7) Special Hazard Systems (MDF or IDF rooms.)
- 8) Standpipe systems.
- 9) Free standing yard fire department connections.
- 10) Fire pumps.
- 11) Parking fees / Drain fees.
- 12) All existing areas.

# SUPERHERO FIRE PROTECTION

## Conditions of Proposal

### COHS Parking Deck

May 11, 2026

Page 3 of 3

1. Acceptance of this proposal by Buyer shall be acceptance of all terms and conditions recited herein or incorporated by reference. Allowing SuperHero Fire Protection (herein referenced to as SHFP) to commence work or preparation for work will constitute acceptance by the Buyer of this proposal and all its terms and conditions Quotations herein, unless otherwise stated are for immediate acceptance and subject to change.
2. After acceptance of this Proposal as provided, SHFP shall be given a reasonable time in which to make delivery of materials and/or labor to commence and complete the performance of the contract. SHFP shall not be responsible for delays or defaults where occasioned by any cause of any kind and extent beyond its control, including but not limited to: delays caused by owner, general contractor architect and/or engineers, armed conflict or economic dislocation resulting therefrom, embargoes, shortages of labor, raw materials production facilities or transportation, labor difficulties, civil disorders of any kind, action of civil or military authorities, vendor priorities and allocations, fires, floods, accidents and acts of God.
3. Work called for herein is to be performed during SHFP's regular working hours. Overtime rates will be charged for all work performed outside such hours as extra cost.
4. SHFP will not be responsible for meeting construction schedules imposed after the date of the execution of this Proposal. If overtime is required to meet such a later imposed construction schedule, Buyer shall pay SHFP for such overtime, in addition to the
5. Buyer is to prepare all work areas so as to be acceptable for SHFP's work under the contract. SHFP will not be called upon to start work until sufficient areas are ready to insure continued work until job completion.
6. The Buyer shall furnish all temporary site facilities including suitable covered and storage spaces and hoisting at to cost to SHFP.
7. Buyer shall purchase and maintain property insurance upon the full value of the entire work and / or materials to be supplied which shall include the interest of SHFP.
8. All materials shall be furnished in accordance with the respective industry tolerance of thickness, size, finish and performance
9. All workmanship is guaranteed against defects for a period of one year from the date of installation. The warranty is in lieu of all other warranties expressed or implied including any warranties of merchantability of fitness for a particular purpose. SHFP will not be responsible for special, incidental, or consequential damages. SHFP shall not be responsible for damage to its work by other parties. Any repair work necessitated by caused damage will be considered as an order for extra work.
10. If the Buyer fails to make payment to SHFP as herein provided, then SHFP may stop work without prejudice to any other remedy he may have.
11. All sums not paid when due shall bear interest at the rate of 1-1/2% per month from due date until paid or the maximum legal rate permitted by law whichever is less; and all cost of collection, including reasonable attorney's fee, shall be paid by Buyer.
12. No back charges or claim of the Buyer for services shall be valid except by the agreement in writing by SHFP before work is
13. Notwithstanding any provision contained in this Proposal or the contract documents between Owner and Contractor, SHFP may file a lien or claim on its behalf in the event that any payment to SHFP is not made as when provided for by the agreement.
14. Any additional materials and / or labor required due to alterations or additions to the premises or resulting from obstruction not in position at the time of SHFP's survey or not shown on the plans furnished by Buyer or Buyer's Agent are not contract work and are to be considered additional work which is to be paid for by Buyer at SHFP's current market price.
15. The Buyer shall make no demand for liquidated damages for delay or causes for delays in any sum in excess of such amount as may be specifically named in the proposal and no liquidated damages may be assessed against SHFP for delays or causes attributed to other contractors or rising outside the scope of this proposal.
16. Should this Proposal not be accepted as a binding contract, this Proposal and all its specifications, terms and conditional shall be incorporated into the subcontract document. Where there is a conflict between provisions of either the subcontract or the contract between Owner and Contractor and this Proposal, this this Proposal shall govern.



1865 Corporate Drive Suite 220 • Norcross, Georgia 30093 • 678.392.3146 • SCR - G-0558 • RME G-0896

May 11, 2026

Bid Proposal # ATLS-24-0238  
 Estimator: Colton Sawyer  
 Csawyer@shambaugh.com

**Holly Springs Parking Deck**

**Pricing based on:**

Attention: Estimating  
  
 Reference: Holly Springs Parking Deck  
 271 Hickory Rd  
 Holly Springs, GA

FP/Plumb.Dwg's: Division 21 and or FP Dwg's  
 Specifications: Division 21 and or FP Dwg's  
 Addendum: 0  
 Doc Date: 7/29/2025  
 Version: FP Revisions

S&S Fire Protection, is pleased to provide you with the following quote on the above reference project.

**SCOPE: Install Fire Sprinkler System per NFPA 13,14, local Codes and Division 21.**

- 1 Begin our work inside building at a flange above finish floor for the fire service line and if applicable remote fire department connections. We are excluding all fire protection underground piping work, PIV's, hydrants, valves, underground vaults with water meters and backflow preventers, all flushing, chlorination, and testing as per NFPA and local water company requirements.
- 2 We include all design/BIM/Submittals and permit fees as required for a complete operating fire system.
- 3 Manual Dry Standpipe with 2.5" Fire Hose Valves located per AHJ requirements utilizing blk steel sch 10 pipe with welded outlets and grooved ends.
- 4 All systems shall be hydraulically designed per plans and AHJ Requirements.
- 5 No allowance has been made to supply or install materials, devices, or additional hangers to improve the structural strength of the building or to enable it to handle the weight of the sprinkler system.
- 6 We assume our work will occur during normal working hours. We assume a standard 40-hour work week.
- 7 We include the fees associated with Textura.
- 8 Sales Tax is Included.

XI. We exclude the following items:

- a. Corrosion resistant sprinklers (UNO)
- b. All painting of pipe, fittings, equipment and/or protection of sprinkler heads from paint.
- c. We exclude custom color sprinklers or plates. If custom colored sprinklers or plates are required we will need to seek additional compensation based on each separate color and total quantity of each color.
- d. Electrical or alarm wiring.
- e. Water supply tap, supply to valve pit, valve pit, supply pipe to building, and tap fees.
- f. Microbial Influenced Corrosion (MIC) testing, treatment, or monitoring.
- g. Knox box.
- h. Fire hose racks, fire extinguishers and cabinets
- i. Any general construction work (i.e. concrete pads, water, power, heat, etc.)
- j. Installation of access panels.
- k. The cost for penetrations/sleeving of any beams if required for sprinkler piping.
- l. Performance and Payment Bonds Add 1.25% of base contract.
- m. Certified Fire Protection Engineer (FPE) stamped review and approval fees. We have included the signature of a NICET certified designer.
- n. The cost for obtaining AutoCAD background files.
- o. Dedicated Safety/Commissioning person to project our working foreman will take on these responsibilities.
- p. Safety items above and beyond OSHA standards.
- q. Exterior Balconies/Overhangs/Attic Spaces
- r. Fire Hose Valve Cabinets
- s. Vibration Control/Seismic



1865 Corporate Drive Suite 220 • Norcross, Georgia 30093 • 678.392.3146 • SCR - G-0558 • RME G-0896

- t. Acoustical Caulk/Sound Caulk
  - u. Heat Trace or Insulation
  - v. No Architecturally Placed Sprinkler Heads, units numbers will be provided if required.
  - w. Overtime/Shift Work.
  - x. Composite cleanup crew- We will cleanup our own identifiable trash/scrap.
  - y. Special Systems: Dry, PreAction, Clean Agent, Kitchen hoods, PCU, Exhaust ducts or Antifreeze Systems.
  - z. Adequate water supply: Site to have sufficient water @ 20psi per IFC, bldg. type & structure height.
- X2. S&S Fire Protection reserves the right to negotiate subcontract terms and conditions that are fair and mutually agreeable to both parties.

**CLARIFICATIONS & SPECIFIC EXCLUSIONS**

- Safety info: EMR: 2019-0.55, 2020-0.58, 2021-0.58, 2022-0.67, 2023-0.68, 2024-0.65, 2025-0.64
- Flushing and testing of all new underground fire mains needs to be completed by the installing site utility contractor per NFPA and the local water utility requirements per NFPA 13 and State Insurance laws.
- Temp. Standpipe to be installed in permanent stairs per IFC once bldg. exceeds 40ft above fire dept. access, if this can not be accomplished due to stairs not being installed or temp scaffold stairs are provided then NSFP reserves the right to request an extra at that time. Est. cost per level per Temp Standpipe: \$750.00 includes FHV and labor.
- U.N.O Exterior Balconies & overhangs are excluded from this bid.

**ALTERNATES: (Not included in base bid)**

No 24hr air pressure test at 40 psi	\$	5,500	<b>DEDUCT FROM BASE BID</b>
(6) 2.5" FHV in lieu of Storz Connection	\$	1,450	<b>ADD TO BASE BID</b>
	\$	-	

❖ Due to the volatility of steel pricing, this quote is valid for 30-days from the date of this proposal. We reserve the right to adjust pricing after that date.

<b>BASE BID PRICING:</b>	Holly Springs Parking Deck		
\$	<b>126,546</b>	<b>Subtotal</b>	
\$	<b>2,910</b>	<b>Tax</b>	
<hr/>			
\$	<b>129,456</b>	<b>Base Bid Fire Protection Without Bond</b>	
\$	<b>1,618</b>	<b>Bond @ 1.25%</b>	
<hr/>			
\$	<b>131,074</b>	<b>Total</b>	

We thank you for this opportunity in offering you our services and hope to be working with you in the near future.

If you have any questions, please do not hesitate to call.

Sincerely,

*Colton Sawyer*

Colton Sawyer  
Csawyer@shambaugh.com

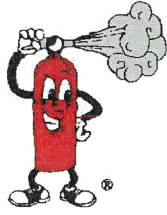

# CLIFF'S FIRE EXTINGUISHER CO., INC.

311 Bell Park Drive, Woodstock, GA 30188  
Phone: 770-591-5271 Fax: 770-591-4033



To:	<b>Stonecrest Homes</b>	Proposal Date:	<b>05/08/2026</b>
Address:		Proposal No:	<b>CFE-13982</b>
ATTN:		Site Address:	<b>Holly Springs Parking Deck, 241 Hickory Road, Holly Springs, GA 30115</b>

We propose to provide the following scope of work as described below at the above location for the sum of **\$126,750.**

### SCOPE OF WORK

Beginning at a properly flushed flange 1-0 AFF and install a dry standpipe system. **Excluded is all underground work.**

The owner will provide cad files at no cost to Cliff's Fire Extinguisher Co.

TERMS: Pending mutual agreement of Contract Terms.

We reserve the right to send partial billings for projects based on work completed. Payment due according to agreed upon terms.

Customer is responsible for providing access to all areas. **All Return Trips** related to lack of access will be subject to a **minimum service fee of \$300.00**, depending upon distance and services provided.

**EXCLUDED FROM OUR WORK IS:** Backflow preventer, painting, prepping pipe for painting, patching, alarms, wiring of alarms, cutting and patching floors, drives and walls, freeze protection. All doors, wall and equipment that must be removed and/or reinstalled. This work must be completed by someone else. No seismic protection required, **assumes adequate water.**

This price subject to revision if not accepted within thirty (30) days. We thank you for the privilege of submitting this proposal.

Respectfully,  
Cliff's Fire Extinguisher Co.

By: Louie Lincoln  
Manager

Purchaser's written execution of this proposal shall constitute acceptance thereof and shall be deemed to form a written contract between the parties that specifically includes all terms and conditions set forth in this agreement, including items 1 - 16 in the terms and conditions listed below.

COMPANY \_\_\_\_\_

ACCEPTED BY (PRINT) \_\_\_\_\_

TITLE \_\_\_\_\_

SIGNATURE \_\_\_\_\_

DATE \_\_\_\_\_

## PROPOSAL TERMS AND CONDITIONS

1. Systems Installation - Purchaser shall furnish all necessary facilities for performance of the work by CLIFFS FIRE EXTINGUISHER CO, including site access, adequate space for storage and handling of material, light, water, heater, local telephone, watchman, crane, elevator service (if available), and all necessary permits. Except where dry pipe or anti-freeze type system is installed, Purchaser shall supply and maintain sufficient heat to prevent freezing of system. Purchaser shall furnish all necessary plans, specifications, drawings, contract documents, project schedules, or any revisions thereto to CLIFFS FIRE EXTINGUISHER CO.
2. System Alignment - Purchaser agrees that the sprinkler heads with piping concealed above ceiling tile, are to be located and aligned symmetrically within normal fabrication and installation tolerances to be established by CLIFFS FIRE EXTINGUISHER CO. Unless otherwise agreed in writing, Purchaser agrees sprinkler heads are not required to be centered in suspended ceiling tile (center of tile), and that precise location of sprinkler heads shall be determined by CLIFFS FIRE EXTINGUISHER CO.
3. Excavation - When CLIFFS FIRE EXTINGUISHER CO does excavations, if water, quicksand, rock or other unforeseen obstructions are encountered or shoring is required, Purchaser shall pay for, as an extra to the contract price, the additional expense involved. All underground installations are based on four feet maximum bury and any greater depth will be an extra to the contract price.
4. Damage - While employees of CLIFFS FIRE EXTINGUISHER CO will exercise reasonable care in the performance hereunder, CLIFFS FIRE EXTINGUISHER CO shall be under no responsibility for loss or damage due to the character, condition or use of foundations, walls or other structures not erected by it or resulting from excavation in proximity thereto, nor for damage resulting from concealed piping, wiring, wiring fixtures or other equipment or condition of water pressure. All shoring or protection of foundations, walls or other structures subject to being disturbed or any excavation required hereunder, shall be the responsibility of the Purchaser unless otherwise specified. Purchaser warrants the sufficiency of the structure to support the sprinkler system and its related equipment (including tanks).
5. Changes in Scope of Work - All installation will be made in accordance with a survey by CLIFFS FIRE EXTINGUISHER CO of the premises based on the present or proposed type of occupancy. If any changes in said system are required by any change in type of occupancy, or by obstructions not in position when said survey was made, or not indicated on plans furnished to CLIFFS FIRE EXTINGUISHER CO or by reasons of any alterations of, or additions to extensions to said premises, Purchaser agrees to pay to CLIFFS FIRE EXTINGUISHER CO any additional cost in performing this contract.
6. Delay - If CLIFFS FIRE EXTINGUISHER CO is delayed at any time in performing its work by an act or neglect of the Purchaser, an architect, engineer, building official / inspector or third party or by labor disputes, fire, unusual delay in deliveries, weather, other Acts of God, unavoidable casualties or other causes beyond CLIFFS FIRE EXTINGUISHER COs control, then the time for CLIFFS FIRE EXTINGUISHER CO to perform its work shall be extended a reasonable period of time. Under no circumstances shall CLIFFS FIRE EXTINGUISHER CO be liable for direct or indirect damages for any delay in performing its work.
7. Working Hours - All installation work will be performed during normal working hours. If Purchaser shall require any overtime labor, Purchaser agrees to reimburse CLIFFS FIRE EXTINGUISHER CO for the overtime premium for same with the next billing of CLIFFS FIRE EXTINGUISHER CO to Purchaser. CLIFFS FIRE EXTINGUISHER COs normal hours are 7:30 a.m. to 5:30 p.m., Monday thru Thursday.
8. Warranty - CLIFFS FIRE EXTINGUISHER CO agrees that for a period of one (1) year after completion of the installation of CLIFFS FIRE EXTINGUISHER COs work or substantial completion of the project, whichever shall first occur, it will make, at its expense, all repairs to its own work made necessary by defective materials or workmanship. This obligation shall not apply to any installation work that has been altered or utilized in a manner not approved by CLIFFS FIRE EXTINGUISHER CO or subjected to accidents, negligence, abuse, misuse, unauthorized use, improper maintenance or damage through no fault of CLIFFS FIRE EXTINGUISHER CO.
9. Liability - All loss or damage for any cause (not the fault of CLIFFS FIRE EXTINGUISHER CO) to the materials, tools, equipment, work or workmen of CLIFFS FIRE EXTINGUISHER CO or its agent or subcontractors while in or about the premises of the Purchaser shall be borne and paid for by the Purchaser. The Purchaser shall provide and maintain insurance to protect the project and CLIFFS FIRE EXTINGUISHER COs work from any kind of peril of physical loss and shall cause CLIFFS FIRE EXTINGUISHER CO to be named as an additional insured under this insurance policy.
10. Bonds - CLIFFS FIRE EXTINGUISHER CO shall furnish to Purchaser, within ten (10) days of written demand, copies of all required bonds which provide coverage for materials delivered or furnished and labor performed at the project site (these bonds to be paid for by Purchaser), however, the bonds will not be transmitted to the Purchaser until an executed contract is received by CLIFFS FIRE EXTINGUISHER CO.
11. Assignment by Purchaser - This proposal may not be assigned by Purchaser without written consent of CLIFFS FIRE EXTINGUISHER CO.
12. Terms of Payment - Invoices will be rendered representing the value of materials delivered to the site and work performed. All such invoices are payable in full within thirty (30) days. 2% interest per month will be added to past due invoices. If payment is not received in full by the 51st day, the unpaid amount will be subject to an additional 20% collection fee.
13. Revocation of Bid - This bid is revocable at any time prior to signed acceptance by the Purchaser.
14. Default - In case of default by Purchaser, CLIFFS FIRE EXTINGUISHER CO may declare the contract price or all unpaid installments thereof to be immediately due and payable (whether or not said installation shall have been completed), or may enter said premises and shut off the water from said system or remove all or any portion of the same. All such remedies of CLIFFS FIRE EXTINGUISHER CO are cumulative. Default by Purchaser shall consist of; failure to pay any monthly invoice when due, no demand being necessary or any act of omission on the part of the Purchaser whereby CLIFFS FIRE EXTINGUISHER CO is prevented from completion of said installation, or receivership, bankruptcy, assignment for the benefit of credits or any other form of insolvency proceedings by or against Purchaser or in case said premises or said system shall be attached, lien or seized by process of law and such attachment or lien shall not be vacated or seizure terminated within ten

(10) days after its occurrence. Should the contract price or any portion thereof, not be paid as set forth above, then Purchaser agrees to pay all costs, including reasonable attorney fees, incurred by CLIFFS FIRE EXTINGUISHER CO as a result thereof and is not conditioned upon suit actually being filed.

15. Legal Action - Purchaser and CLIFFS FIRE EXTINGUISHER CO agree that venue and jurisdiction for any suit or other legal action under this purchase order shall lie in CherokeeCounty, Georgia and further agree that any suit or other legal action under this proposal shall be filed in a state court located in CherokeeCounty, Georgia.

16. Conflicts - It is expressly agreed there are no promises, agreements or understandings not set forth in this proposal and the proposal supersedes all prior negotiations, representations or agreements, either written or oral. In the event of a variance or conflict between any contract, agreement, plan, specification, drawing or other contract document and this proposal, then the terms of this proposal shall govern and take precedent over such conflicting term.

# ITEM REPORT

**AGENDA ITEM NUMBER: VIII.F.**



**FROM:** Robert H. Logan, City Manager

**MEETING DATE:** May 21, 2026

**AGENDA ITEM:** Estimate #0332 from KAM Contracting Southeast, LLC for sanitary sewer changes and stormwater sewer changes in the Holly Springs Town Center in an amount not to exceed \$83,550.

---

## **EXECUTIVE SUMMARY:**

The City of Holly Springs requested and received three quotes for the performance of sanitary sewer and stormwater sewer work within the Holly Springs Town Center. The project includes the installation of sanitary sewer clean-outs A-1 through A-5 with a grease trap and manhole for the dumpster pad, installation of sanitary sewer clean-outs C-1 and B-2 for the Social Building, adjustment of five (5) sanitary sewer tops, and revision of the sanitary sewer clean-out at the maximum invert elevation of 1072 to service the restrooms in the basement of City Hall. The project also includes the relocation of stormwater sewers CI, AA-1, and AA-2, an extension of the stormwater sewer at JB B21, the addition of stormwater sewer at DI B22 for the Social Building and parking lot, extension of the stormwater sewer from EX CI Y11 and installation of CI Y12 to serve the surface parking lot adjacent to the parking deck.

## **IS THIS A BUDGETED ITEM?**

Yes

## **FUNDING SOURCE:**

Bond Revenue

## **FISCAL IMPACT:**

\$83,550

## **ATTACHMENTS:**

1. Quotes for Storm & Sewer REV - Town Center
2. Exhibits for Storm & Sewer REV - Town Center

**RECOMMENDATION:**

The staff recommendation is approval of the quote/estimate.

**CONCURRENCES:**

Finance and Administration

KAM Contracting Southeast, LLC

524 Crested Hawk Ridge  
Canton, GA 30114

# Estimate

Date	Estimate #
5/7/2026	0332

Name / Address
HOLLY SPRINGS TOWN CENTER EXTRA REVISIONS

			Project
Description	Qty	Cost	Total
SANITARY FIND PLUG AND REMOVE PER REQUEST	1	500.00	500.00
ADD CLEANOUTS A-1 TO A-5 WITH 1500 GALLON GREASE TRAP AND TEST MANHOLE FOR PROPOSED DUMPSTER PAD IN PROPOSED PARKING AREA	1	33,200.00	33,200.00
INSTALL PROPOSED CLEANOUTS C-1 AND B-2 TO SERVICE THE PROPOSED INDOOR SOCIAL BUILDING	2	3,400.00	6,800.00
ADJUST SANITARY SEWER TOPS AS NECESSARY EACH AS NEEDED	5	850.00	4,250.00
REINSTALL CITY HALL SANITARY CLEANOUT TO MAX INVERT ELEVATION OF 1072	1	12,200.00	12,200.00
TESTING required CCWSA for the segment of sanitary per the attached AREA SHOWN IN GREEN ON PLAN	1	3,750.00	3,750.00
STORM			
RELOCATE STORM CI AA-1 AND AA-2 AND DEMOLISH/ REUSE PER PLAN	1	8,700.00	8,700.00
EXTEND STORM LINE FROM JB B21 AND ADD DI B22 TO SERVICE FUTURE INDOOR SOCIAL PARKING LOT DRAIN	1	6,000.00	6,000.00
EXTEND STORM LINE FROM EX CI Y11 AND INSTALL PROPOSED CI Y12 TO SERVICE PARKING LOT NEXT TO PARKING DECK	1	8,150.00	8,150.00
		<b>Total</b>	

Customer Signature

KAM Contracting Southeast, LLC

524 Crested Hawk Ridge  
Canton, GA 30114

# Estimate

Date	Estimate #
5/7/2026	0332

Name / Address
HOLLY SPRINGS TOWN CENTER EXTRA REVISIONS

Project

Description	Qty	Cost	Total
NOTES LANDSCAPE BY OTHERS LAYOUT AND AS BUILTS BY OTHERS -APPROVED PLANS WILL AFFECT FINAL BID -SOIL TESTING BY OTHERS -FEE'S, PERMITS, ETC BY OTHERS -METERS BY THE OTHERS -ROCK HAMMER IS \$3,850.00 PER DAY WITH 2 DAY MIN AND \$1,000 MOBILIZATION -DEWATERING WILL BE ADDITIONAL BY THE DAY BASED ON PUMP SIZE -TRENCH ROCK BLASTED AND DISPOSED OF IN THE DITCH \$76.00 PER CY -MASS ROCK BLASTED AND DISPOSED OF ON SITE \$32.00 PER CY -BLASTING MOBILIZATION AND MONITORING IS ADDITIONAL -CUTTING ASPHALT AND STREET REPAIRS BY OTHERS -EXPORT OF UNSUITABLES NEGOTIATED ON SITE -IMPORT OF GOOD FILL MATERIAL NEGOTIATED ON SITE			
		<b>Total</b>	\$83,550.00

Customer Signature \_\_\_\_\_

# Darrell C Dinsmore Grading, Inc.

1995 Dr. Bramblett Road  
Cumming, Ga 30028

Phone: 770-781-4347  
Fax: 770-781-9696

## Holly Springs Town Center

Proj: Utility Plan - Town Center North  
To: City of Holly Springs  
3237 Holly Springs Parkway  
Canton, Ga 30142  
Attn: Mr. David Edwards  
Date: 5/7/2026  
From: Jesse Tobias

Item #	Work Description	Quantity	Unit	Unit Price	Total
<b>1A</b>	<b>General Site Conditions</b>	1.00	L.S.	3,500.00	<b>3,500.00</b>
<b>1</b>	<b>Sanitary</b>				<b>44,745.00</b>
A	6" Dumpster Drain and Trap Assembly	1.00	L.S.	2,600.00	2,600.00
B	6" PVC	110.00	L.F.	35.00	3,850.00
C	6" PVC Cleanout	4.00	Each	500.00	2,000.00
D	1500 Gallon Grease Trap	1.00	Each	9,500.00	9,500.00
E	Test Manhole	1.00	Each	3,500.00	3,500.00
F	6" PVC Wye	2.00	Each	275.00	550.00
G	Cleanout Box (Left Onsite, Set by Others)	4.00	Each	450.00	1,800.00
H	Tie to Existing Sewer	1.00	L.S.	2,500.00	2,500.00
I	Bedding Stone	36.00	Tons	65.00	2,340.00
J	Adjust Existing MH	1.00	Each	1,000.00	1,000.00
K	Tie to Existing Sewer Laterals	1.00	L.S.	1,000.00	1,000.00
L	6" PVC	147.00	L.F.	35.00	5,145.00
M	6" PVC Cleanout	3.00	Each	500.00	1,500.00
N	6" PVC Wye	4.00	Each	275.00	1,100.00
O	Bedding Stone	54.00	Tons	65.00	3,510.00
P	Cleanout Box (Left Onsite, Set by Others)	3.00	Each	450.00	1,350.00
Q	Testing	1.00	L.S.	1,500.00	1,500.00
<b>2</b>	<b>Relocation of Existing Clean Out</b>				<b>24,145.00</b>
A	Locate Existing Utilities	1.00	L.S.	1,500.00	1,500.00
B	Saw Cut Asphalt	1.00	L.S.	250.00	250.00
C	Dumpster (Haul off Asphalt and Curb)	1.00	Each	650.00	650.00
D	Trench Box	1.00	Each	2,500.00	2,500.00
E	Pipe Crew Labor	30.00	HR	195.00	5,850.00
F	Excavator	30.00	HR	235.00	7,050.00
G	Trench Roller	15.00	HR	75.00	1,125.00
H	6" PVC Material	1.00	L.S.	1,250.00	1,250.00
I	Bedding Stone	18.00	Tons	65.00	1,170.00
J	8" Concrete Cap in Roadway	6.00	C.Y.	300.00	1,800.00
K	Testing	1.00	L.S.	1,000.00	1,000.00
	***Investigation of water retention in man hole not included				

<b>2</b>	<b>Storm</b>				<b>41,110.00</b>
A	Demo Existing Storm and Boxes	1.00	L.S.	2,500.00	2,500.00
B	Modify Existing MH	1.00	L.S.	1,250.00	1,250.00
C	48" Precast Manholes	15.00	V.F.	350.00	5,250.00
D	1019 Grate and Fame at Curb Line	2.00	Each	1,100.00	2,200.00
E	15" RCP Class III (0-10)	24.00	L.F.	60.00	1,440.00
F	RCP Freight	1.00	Each	650.00	650.00
G	12" HDPE	66.00	L.F.	30.00	1,980.00
H	Rebuild Existing Inverts	3.00	Each	650.00	1,950.00
I	48" Precast Manholes	12.00	V.F.	350.00	4,200.00
J	12" HDPE	20.00	L.F.	30.00	600.00
K	Invert Concrete	2.00	Each	500.00	1,000.00
L	1019 Grate and Fame at Curb Line	1.00	Each	1,100.00	1,100.00
M	Ring and Cover (Junction Box)	1.00	Each	700.00	700.00
N	Modify Existing MH	1.00	L.S.	1,250.00	1,250.00
O	48" Precast Manholes	5.00	V.F.	350.00	1,750.00
P	12" HDPE	46.00	L.F.	30.00	1,380.00
Q	1019 Grate and Fame at Curb Line	1.00	Each	1,100.00	1,100.00
R	Rebuild Existing Inverts	1.00	Each	650.00	650.00
S	Invert Concrete	1.00	Each	500.00	500.00
T	Bedding Stone	72.00	Tons	65.00	4,680.00
U	48" Precast Manholes	4.00	V.F.	350.00	1,400.00
V	12" HDPE	66.00	L.F.	30.00	1,980.00
W	1019 Grate and Fame	1.00	Each	1,100.00	1,100.00
X	Invert Concrete	1.00	Each	500.00	500.00
***6" Roof Leaders are not included.					

**Total: \$ 113,500.00**



6025 Matt Highway  
 Cumming, GA 30028  
 770.888.2224 OFFICE  
 678.947.3672 FAX

## Proposal

**Holly Springs Mixed Use**

**DATE: 03-18-2026**

**SCOPE OF WORK: Storm & Sewer**

- Provide/Install items as listed below.
- Includes all necessary management, materials, equipment, and labor.

Description	Quantity Unit		
<b>Sanitary</b>			
Grease Trap	1.000 EACH		
Sewer Test Manhole	1.000 EACH		
Adjust Top to Grade	8.000 EACH		
6" Cleanout and Box w/Cover	8.000 EACH		
6" PVC SDR 26	220.000 L.F.		
<b>Sub-Total: Sanitary</b>			<b>71,314.56</b>
<b>Storm</b>			
18" RCP III	50.000 L.F.		
48" Drop Inlet	2.000 EACH		
48" Curb Inlet	1.000 EACH		
Relocate/ Adjust 60" Curb Inlet	1.000 EACH		
15" RCP 1-10	20.000 L.F.		
Relocate/ Adjust 48" Drop Inlet	2.000 EACH		
<b>Sub-Total: Storm</b>			<b>35,838.24</b>
<b>QUOTE TOTAL:</b>			<b>107,152.80</b>

**NOTES:**  
 Proposal based upon plans updated: 01-28-26  
 Proposal pricing is valid until April 17, 2026  
 Excludes As-Builts.  
 Excludes Mass Grading.  
 Excludes all permits, and fees.  
 Excludes any replacement of cultivated soils, if required.  
 Excludes any abatement or asbestos testing.  
 Excludes removal of any hazardous material or remediation.  
 Excludes any utility relocates required due to utilities conflicts not shown on plans.  
 This proposal is based upon a classified site condition.  
 Excludes all site amenities, sidewalks, fencing, guardrails - By Others  
 Excludes erosion control BMPs and maintenance.  
 Demo of power and gas utilities by others if necessary.

Excludes NPDES monitoring.  
Excludes all utility fees to CCWSA.  
Excludes water meters, by CCWSA.  
Excludes fire risers.  
Excludes 8" OS&Y Valve.  
Excludes all foundation and ramp walls.  
Silt Fence and Tree Save fence to be removed by others.  
Excludes all dewatering and cleaning of existing utilities.  
Escalation clauses will be included in all contracts.  
Excludes repair or replacement of existing pavements.  
If existing conditions represented by plans or details differ from field conditions additional charges may apply  
Excludes all topsoil placement, landscaping, pond plantings and permanent grassing.  
The proposal will require updating based on agreed upon start date, milestone dates, and completion date.  
Proposal based on maximum retainage of 10% for the first 50% of payments. Upon 50% payment, no further retainage to be withheld.  
At 75% payment, half of the retainage withheld to be returned to Vertical Earth.

**UTILITY NOTE:**

WATER METERS ARE NOT PERMITTED TO BE LOCATED IN DRIVEWAYS.  
 ALL SEWER CLEAROUTS LOCATED IN DRIVEWAY SHALL BE TRAFFIC RATED.  
 QUANTITIES ARE LISTED FOR PERMITTING PURPOSES ONLY.  
 CONTRACTOR IS RESPONSIBLE FOR HIS/HER OWN TAKEOFFS.  
 BUILDINGS) MEP & FIRE PROTECTIONS NOT RECEIVED. WATER & SEWER STUB LOCATIONS WERE ASSUMED & MAY NEED TO BE ADJUSTED BASED ON FINAL ARCHITECTURAL PLANS. FOC LOCATIONS ARE ASSIGNED TO BE LOCATED ON BUILDING.

**CHEROKEE COUNTY WATER AND SEWER:**  
 1) SEE SHEET C1.2 FOR CCWSA WATER AND SEWER NOTES.  
 2) A COPY OF THE CCWSA STANDARD DETAIL BOOKLET SHOULD BE KEPT WITH THE STAMPED PLANS AT ALL TIMES.  
 3) SEWER CLEAROUTS ARE TO BE LOCATED AT THE INSIDE EDGE OF THE RIGHT-OF-WAY.

**LANDSCAPE NOTE:**  
 NO LANDSCAPING (TREES, PLANTS OR SHRUBS) OR STRUCTURES ALLOWED INSIDE CCWSA EASEMENT

**AS-BUILT NOTE:**  
 AS-BUILT RECORD DRAWINGS, AND RECORDED WATER AND OR SEWER EASEMENTS PER CCWSA SPECIFICATIONS, SHALL BE SUBMITTED AND APPROVED BY CCWSA ENGINEERING DEPARTMENTS PRIOR TO THE RELEASE OF ANY METER SALES.

**TOWN CENTER UTILITY QUANTITIES:**

**WATER:**  
 2,413 LF, 8" DIP WATER MAIN  
 263 LF, 7" COUPES WATER SERVICE LINE  
 8 WATER METERS  
 7 FIRE HYDRANTS  
 6 WATER VALVES

**SEWER:**  
 1,518 LF, 8" PVC SDR 35  
 1,015 LF, 8" PVC SDR 35  
 723 LF, 4" PVC SERVICE LINES  
 44 CLEAROUTS  
 10 GREASE TRAPS

**NOTE:**  
 ALL AREAS OUTSIDE OF THE PROPOSED LOTS ARE TO BE DESIGNATED AS COMMON AREAS. THERE WILL BE A MARKED, NON-EXCLUSIVE EASEMENT ACROSS ALL COMMON AREAS FOR HOME OWNER'S ASSOCIATION USE AS NEEDED, INCLUDING BUT NOT LIMITED TO PERPETUAL MAINTENANCE OF ALL INFRASTRUCTURE.

**WATER LINE LEGEND**

	PUBLIC WATER LINE
	PRIVATE WATER LINE

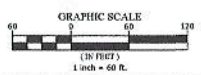

THE UTILITIES SHOWN HEREOF ARE FOR THE CONTRACTOR'S CONVEINENCE ONLY. THERE MAY BE OTHER UTILITIES NOT SHOWN ON THESE PLANS. THE ENGINEER ASSUMES NO RESPONSIBILITY FOR THE LOCATION, DEPTH AND IT SHALL BE THE CONTRACTOR'S RESPONSIBILITY TO VERIFY ALL UTILITIES WITHIN THE LIMITS OF THE WORK. ALL DAMAGE PAID TO EXISTING UTILITIES BY THE CONTRACTOR SHALL BE THE SOLE RESPONSIBILITY OF THE CONTRACTOR. IT IS THE OWNER/DEVELOPER'S RESPONSIBILITY TO VERIFY EXISTING UTILITY CAPACITY PRIOR TO ANYTHING BEING. THE ENGINEER ASSUMES NO RESPONSIBILITY, NEITHER FORWARDED OR SHOWN, REGARDING EXISTING UTILITY LOCATION, CAPACITY OR CONDITION.



NO.	ISSUED DESCRIPTION	DATE
14	PLUMBER NO. 8 PL. 1000 10/18/24	1-28-25
15	UTILITY & GRADING UPDATES, ETC.	02-09-25
16	FULL LIMITS OF PR. W. PROPERTY LINE	10-15-25

**CITY OF HOLLY SPRINGS**  
 3327 HOLLY SPRINGS PARKWAY  
 CANTON, GA 30142  
 PH: 404.535.5333  
 24 HOUR CONTACT INFORMATION  
 DAVID EDWARDS 864.518.2720

**UTILITY PLAN - TOWN CENTER OVER-ALL**  
 HOLLY SPRINGS MIXED-USE LDP  
 PROJECT LOCATED AT:  
 I-1, 306 AND 340 1/2TH DISTRICT  
 CITY OF HOLLY SPRINGS, CHEROKEE COUNTY, GEORGIA



ISSUED FOR REVIEW

Project No: 2024-17-210  
 Designed By: CDE  
 Issue Date: 01.09.2025

**C1.2.1**



**SANITARY SEWER PROFILE VIEW OF DUMPSTER LINE**

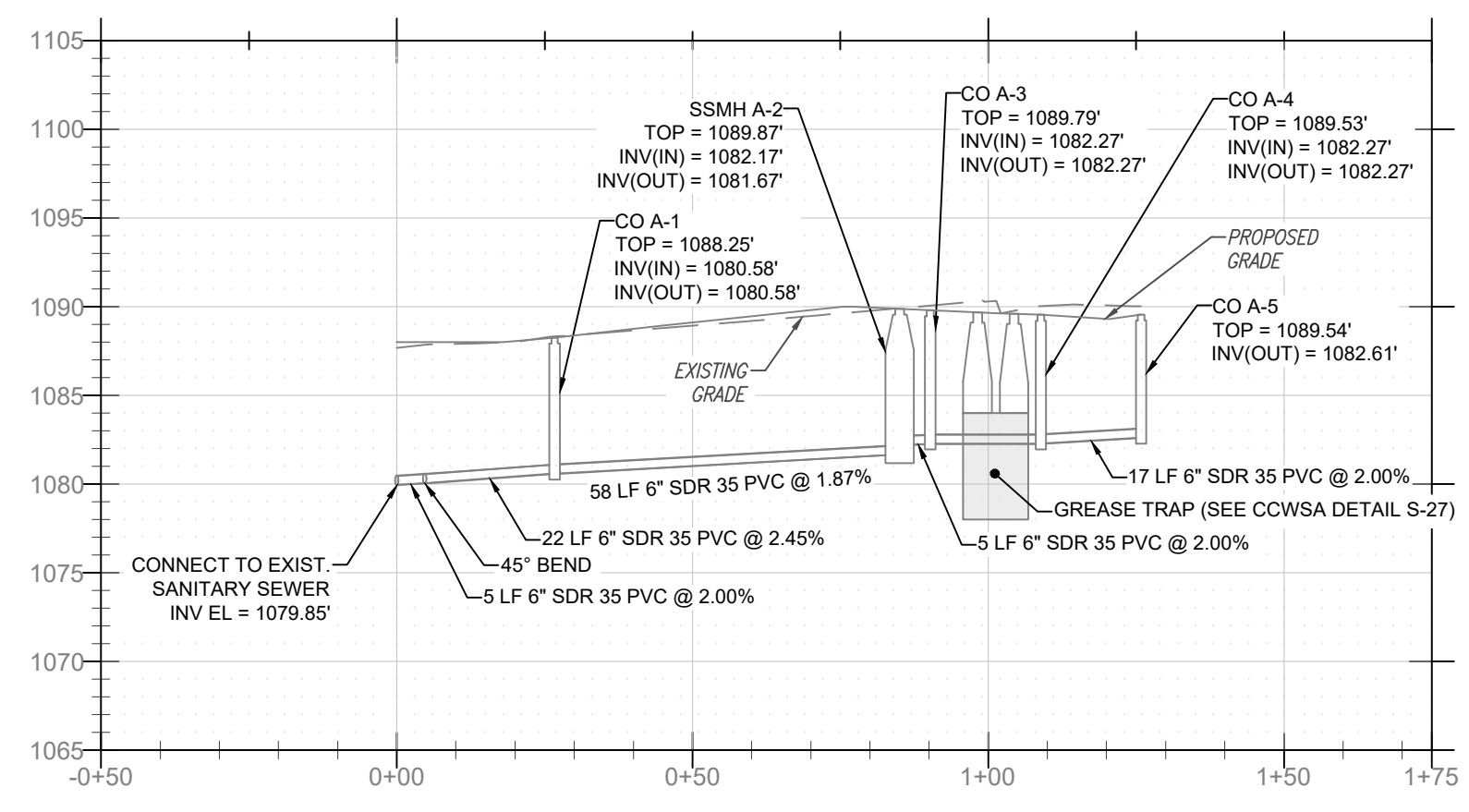

SCALE:  
1" = 30' H  
1" = 10' V

**Water and Sewer Only**

No Exception Noted  Revise and Resubmit  Submit Specified Item   
 Review is for general conformance with the Cherokee County Water and Sewerage Authority standards and in no way releases the developer, property owner, contractor or their agents of the responsibility to comply with the appropriate standards or of any liability for damages to adjacent or downstream properties. This review does not constitute any assumption of liability by Cherokee County Water and Sewerage Authority of the reviewing engineers.  
 Date: 02/03/2026 By: *Jan Night*

APPROVED  
 JOB SITE COPY  
 02/19/2026 3:27:25 PM

**SANITARY SEWER PROFILE VIEW OF INDOOR SOCIAL SEWER**

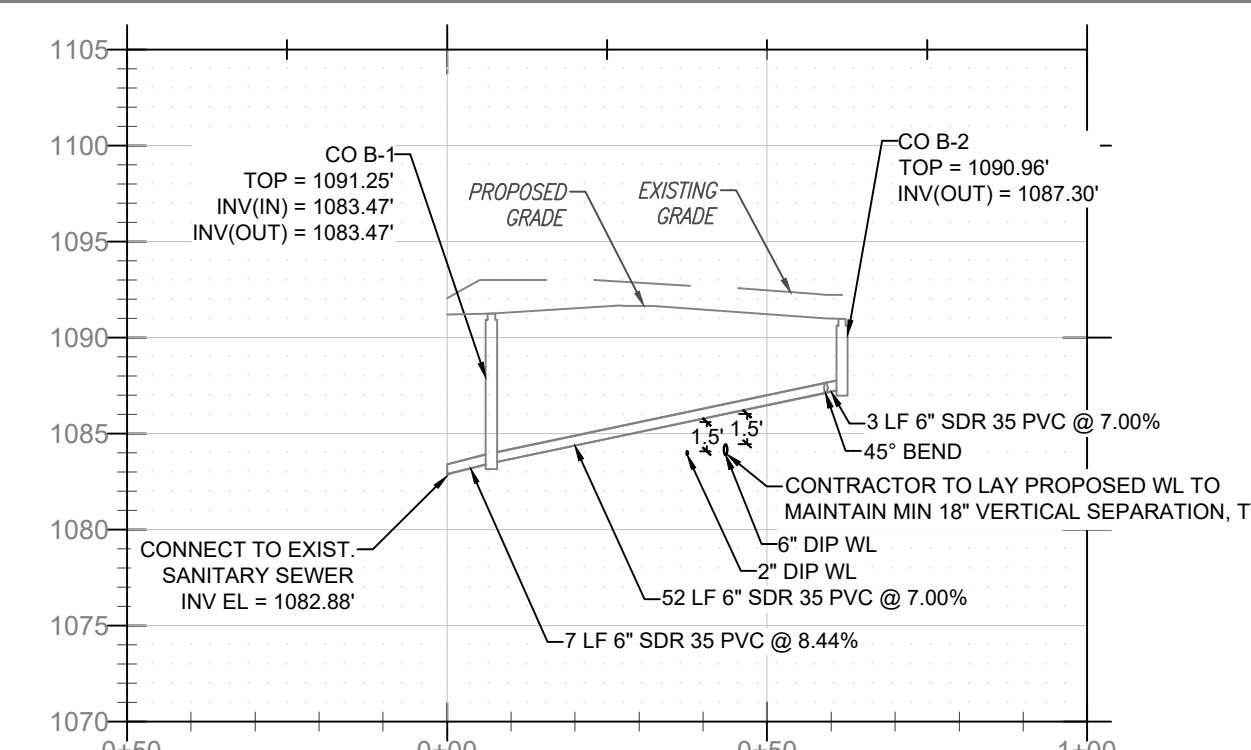

SCALE:  
1" = 30' H  
1" = 10' V

**SANITARY SEWER PROFILE VIEW OF INDOOR SOCIAL GREASE**

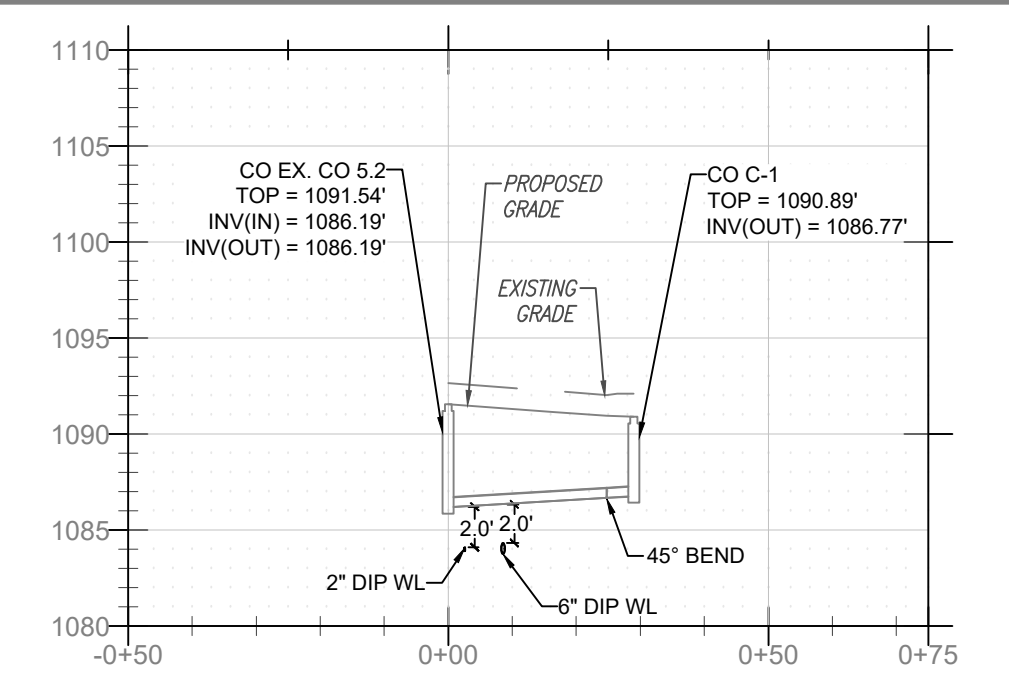

SCALE:  
1" = 30' H  
1" = 10' V

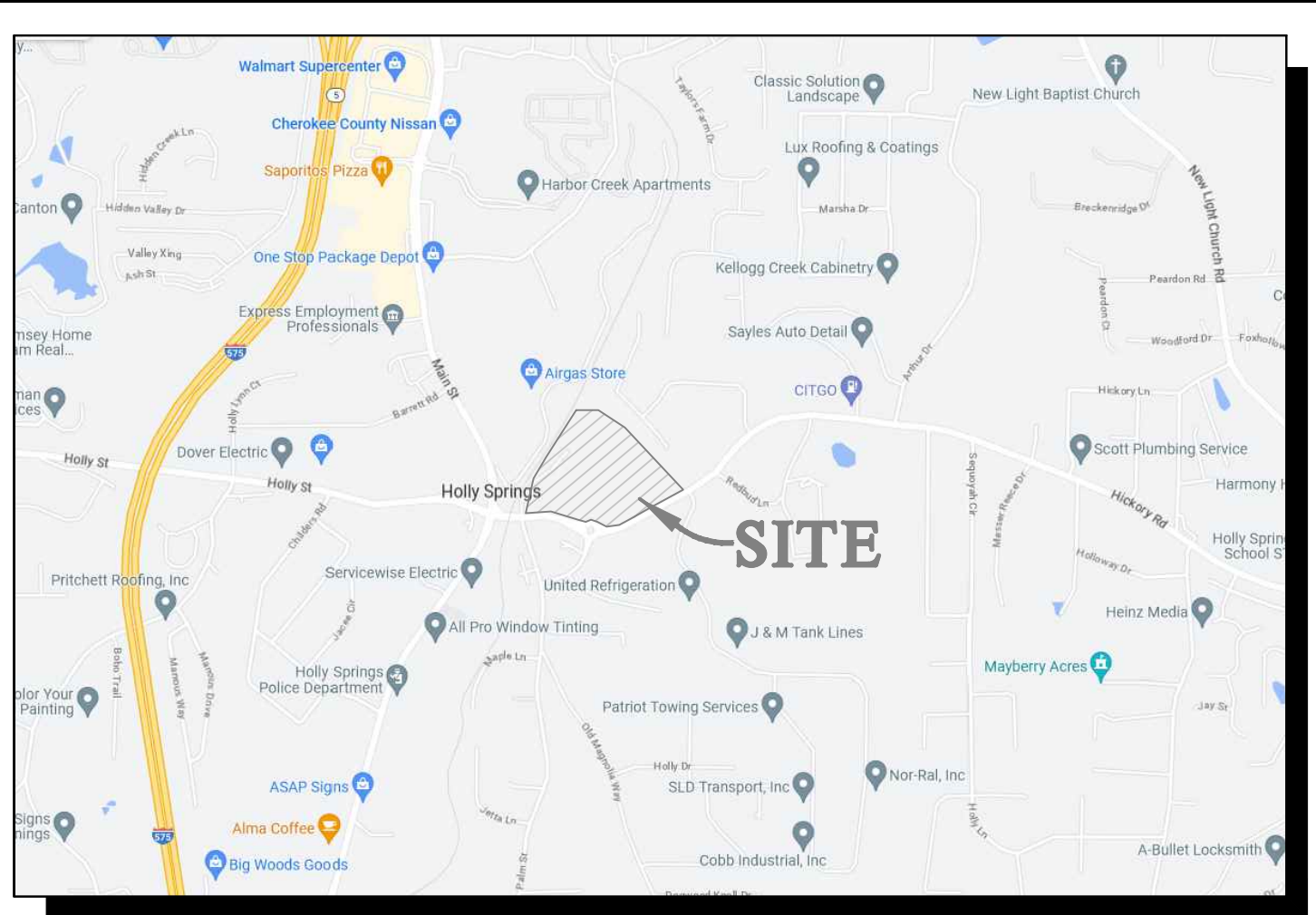
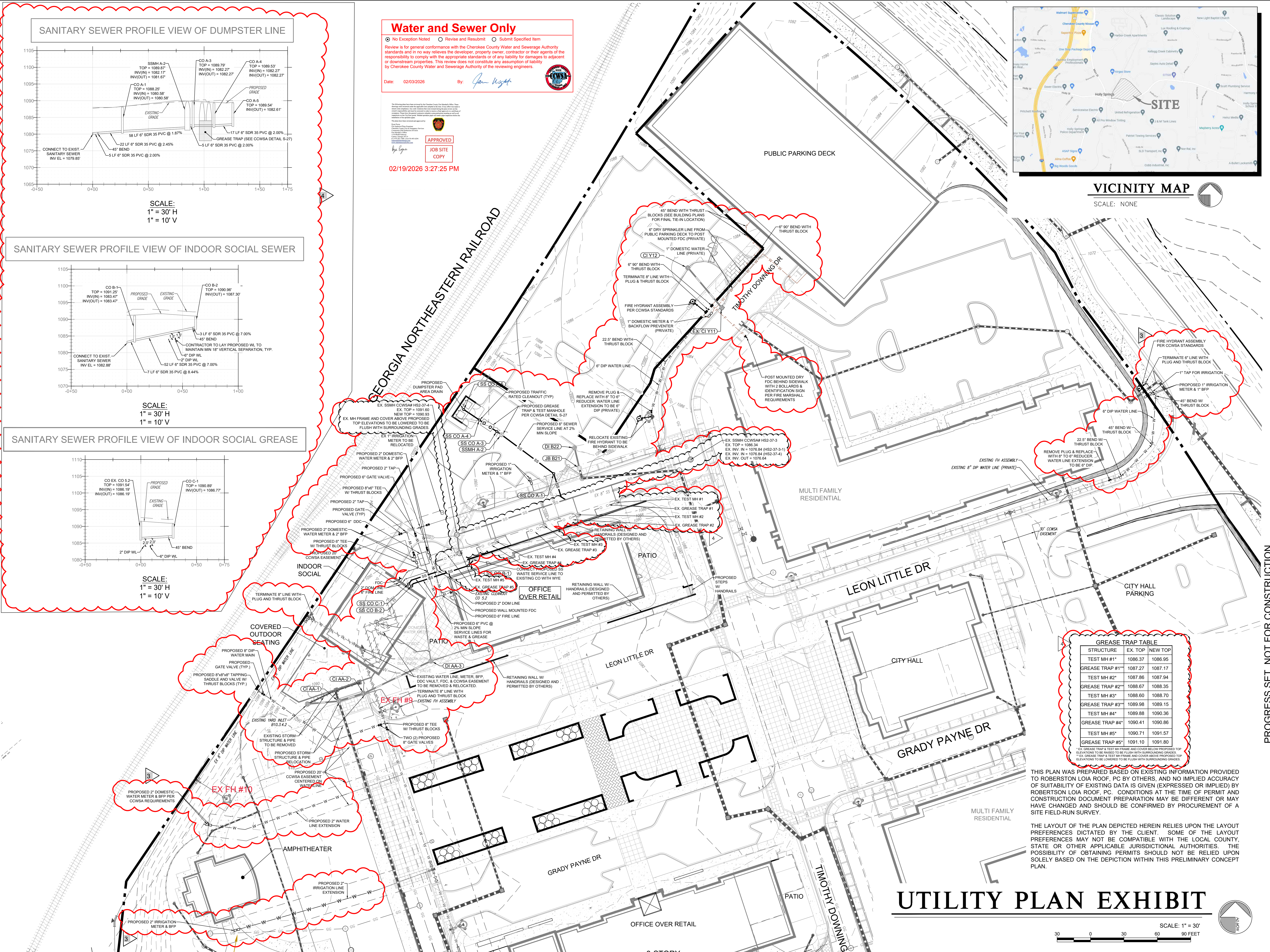

**GREASE TRAP TABLE**

STRUCTURE	EX TOP	NEW TOP
TEST MH #1*	1086.37	1086.95
GREASE TRAP #1**	1087.27	1087.17
TEST MH #2*	1087.86	1087.94
GREASE TRAP #2**	1088.67	1088.35
TEST MH #3*	1088.60	1088.70
GREASE TRAP #3**	1089.98	1089.15
TEST MH #4*	1089.88	1090.36
GREASE TRAP #4**	1090.41	1090.86
TEST MH #5*	1090.71	1091.57
GREASE TRAP #5**	1091.10	1091.80

\* EX. GREASE TRAP & TEST MH FRAME AND COVER BELOW PROPOSED TOP ELEVATIONS TO BE RAISED TO BE FLUSH WITH SURROUNDING GRADES.  
 \*\* EX. GREASE TRAP & TEST MH FRAME AND COVER ABOVE PROPOSED TOP ELEVATIONS TO BE LOWERED TO BE FLUSH WITH SURROUNDING GRADES.

THIS PLAN WAS PREPARED BASED ON EXISTING INFORMATION PROVIDED TO ROBERSTON LOIA ROOF. PC BY OTHERS, AND NO IMPLIED ACCURACY OF SUITABILITY OF EXISTING DATA IS GIVEN (EXPRESSED OR IMPLIED) BY ROBERSTON LOIA ROOF, PC. CONDITIONS AT THE TIME OF PERMIT AND CONSTRUCTION DOCUMENT PREPARATION MAY BE DIFFERENT OR MAY HAVE CHANGED AND SHOULD BE CONFIRMED BY PROCUREMENT OF A SITE FIELD-RUN SURVEY.

THE LAYOUT OF THE PLAN DEPICTED HEREIN RELIES UPON THE LAYOUT PREFERENCES DICTATED BY THE CLIENT. SOME OF THE LAYOUT PREFERENCES MAY NOT BE COMPATIBLE WITH THE LOCAL COUNTY, STATE OR OTHER APPLICABLE JURISDICTIONAL AUTHORITIES. THE POSSIBILITY OF OBTAINING PERMITS SHOULD NOT BE RELIED UPON SOLELY BASED ON THE DEPICTION WITHIN THIS PRELIMINARY CONCEPT PLAN.

**UTILITY PLAN EXHIBIT**

SCALE: 1" = 30'  
 30 0 30 60 90 FEET

**ROBERSTON LOIA ROOF**  
 ARCHITECTS & ENGINEERS  
 3460 Preston Ridge Road - Suite 275 - Alpharetta, GA. 30005  
 770.674.2600 / www.rlrc.com  
 GA.COA # PEF00062 EXPRES 06/30/2026

**HOLLY SPRINGS TOWN CENTER**  
 HICKORY ROAD & BETTY BARRETT WAY  
 HOLLY SPRINGS, GEORGIA  
 FOR: **STONECREST HOMES GA, LLC**  
 625 WEST CROSSVILLE ROAD, STE 204  
 ROSWELL, GEORGIA

REVISIONS

NO.	DATE	DESCRIPTION
1	11/06/2025	CONTRACTOR COMMENTS
2	11/06/2025	CONTRACTOR COMMENTS
3	11/06/2025	CONTRACTOR COMMENTS
4	01/28/2026	GREASE TRAP ADJUSTMENTS

UTILITY PLAN EXHIBIT  
 DATE: 11/06/2025  
 PROJECT NUMBER: 23193  
 SHEET NUMBER: EX-1

PROGRESS SET. NOT FOR CONSTRUCTION.

Utility Plan Exhibit 18, 2025 11-06-2025 (Sheet) 23193-01.dwg (11/06/2025) 11:06:25 AM  
 User: jnight  
 Plot Date: 11/06/2025 11:06:25 AM  
 Plot Scale: 1" = 30' H  
 Plot Orientation: Landscape  
 Plot Size: 11.00 x 17.00  
 Plot Title: UTILITY PLAN EXHIBIT



# ITEM REPORT

**AGENDA ITEM NUMBER: VIII.G.**



**FROM:** Jeff Lance, Captain

**MEETING DATE:** May 21, 2026

**AGENDA ITEM:** Quote # Q-468973 from Power DMS by NeoGov for a subscription services agreement for the use of state certification and policy management software in an amount not to exceed \$10,784.24.

---

## **EXECUTIVE SUMMARY:**

Quote # Q-468973 from Power DMS by NeoGov for a subscription services agreement for the use of state certification and policy management software in an amount not to exceed \$10,784.24. The annual subscription fee will be prorated between Public Safety (85%) and Human Resources (15%).

## **IS THIS A BUDGETED ITEM?**

Yes

## **FUNDING SOURCE:**

General Fund

## **FISCAL IMPACT:**

Public Safety \$9,166.60  
Human Resources \$1,617.64

## **ATTACHMENTS:**

1. PowerDMS

## **RECOMMENDATION:**

The staff recommendation is approval of the annual subscription renewal.

**CONCURRENCES:**

City Manager, Finance, and Administration

THIS IS NOT AN INVOICE

Contract Records		Order Details	
Account Number:	A-27725	Order #:	Q-468973
Customer:	Holly Springs Police Department (GA)	Valid Until:	8/2/2026
Effective Employee Count:	62		
Sales Rep:	Renewals Team		

Customer Contact			
Billing Contact:	Holly Springs Police Department (GA) Jeff Lance	Shipping Contact :	Holly Springs Police Department (GA) Jeff Lance
Billing Address:	3235 Holly Springs Pkwy Canton, GA 30115	Shipping Address:	3235 Holly Springs Pkwy Canton, GA 30115
Billing Contact Email:	jlance@hollyspringsga.us	Shipping Contact Email:	jlance@hollyspringsga.us
Billing Phone:	7707217525	Shipping Phone:	7707217525

Payment Terms		Notes:
Payment Term:	Net 60	
PO Number:		

Subscription Service

Item	Type	Start Date	End Date	Qty.	License Type	Total (USD)
PowerPolicy Professional Subscription	Recurring	9/1/2026	8/31/2027	62	Employee Based	\$8,782.56
A policy and compliance management platform that lets you create, edit, organize, and distribute content from a secure, cloud-based site. Included are key features such as automatic workflows, signature capture and tracking, side-by-side comparison, Public-Facing Documents, PowerDMS University, and Analytics for advanced reporting.						
PowerTraining	Recurring	9/1/2026	8/31/2027	62	Employee Based	\$851.68
A training solution that lets you create, deliver, and track training content online, including videos and PowerPoint presentations. It integrates with PowerPolicy Select and Professional, giving you the ability to attach policies to training courses while ensuring version control. Quantity reflects one agency wide software-as-a-service subscription license up to the employee count specified above.						
PowerStandards for GLECP/GACP	Recurring	9/1/2026	8/31/2027	1	Quantity Based	\$1,150.00
Attach proofs to show compliance with GACP Certification Standard, assign assessment tasks, track revisions, and status-based grading.						
GACP Manual (GA LE)	Recurring	9/1/2026	8/31/2027	1	Quantity Based	\$0.00
View Standards Manual electronically.						
<b>TOTAL:</b>						<b>\$10,784.24</b>

This price does NOT include any sales tax. Total in USD

Additional Terms and Conditions

**License Terms:** Enterprise license denotes that Customer has purchased an enterprise wide license up to the employee count specified above. User based license denotes that Customer has purchased the number of licenses set forth in the quantity column. Item count denotes the number of items that Customer has licensed as set forth in the quantity column.

**Payment Terms:** All invoices issued hereunder are due upon the invoice due date. If the Order is for a period longer than one year, the fees for the first period shown shall be invoiced immediately and the fees for future years/periods shall be invoiced annually in advance of each 12 month period shown on the Order, but regardless of the billing cycle, Customer is responsible for the fees for the entire Order. The fees set forth in this Service Order are exclusive of all applicable taxes, levies, or duties imposed by taxing authorities and Customer shall be responsible for payment of any such applicable taxes, levies, or duties. All payment obligations are non-cancellable, and all fees paid are non-refundable. Payment for services ordered hereunder shall be made to PowerDMS, Inc. a wholly owned subsidiary of Governmentjobs.com, Inc. (D/B/A NEOGOV).



t 800.749.5104  
2120 Park Pl. Suite 100  
El Segundo, CA 90245



**Terms & Conditions:** This Order Form creates a legally binding contract on the parties. Unless otherwise agreed in a written agreement between GovernmentJobs.com, Inc. (D/B/A/ NEOGOV), parent company of PowerDMS, Inc., Cuehit, Inc., Ragnasoft LLC (D/B/A/ PlanIT Schedule), and Design PD, LLC (D/B/A Agency360) (collectively, "NEO GOV") and Customer, this Order Form and the services to be furnished pursuant to this Order Form are subject to the terms and conditions set forth here: <https://www.neogov.com/service-specifications>.

Find a copy of our [W-9 here](#).

Special Condition:

**Your signature below constitutes acceptance of terms herein and contractual commitment to purchase the items listed above.**

Accepted and Agreed By Authorized Representative of:  
**Holly Springs Police Department (GA)**

Signature:

Printed Name:

Title:

Date

THE INFORMATION AND PRICING CONTAINED IN THIS ORDER FORM IS STRICTLY CONFIDENTIAL.